



INSTALLATION INSTRUCTIONS

517

MONITORING SWITCH KITS

ADAMS RITE MODELS: 8300, 8400, 8700 & 8800

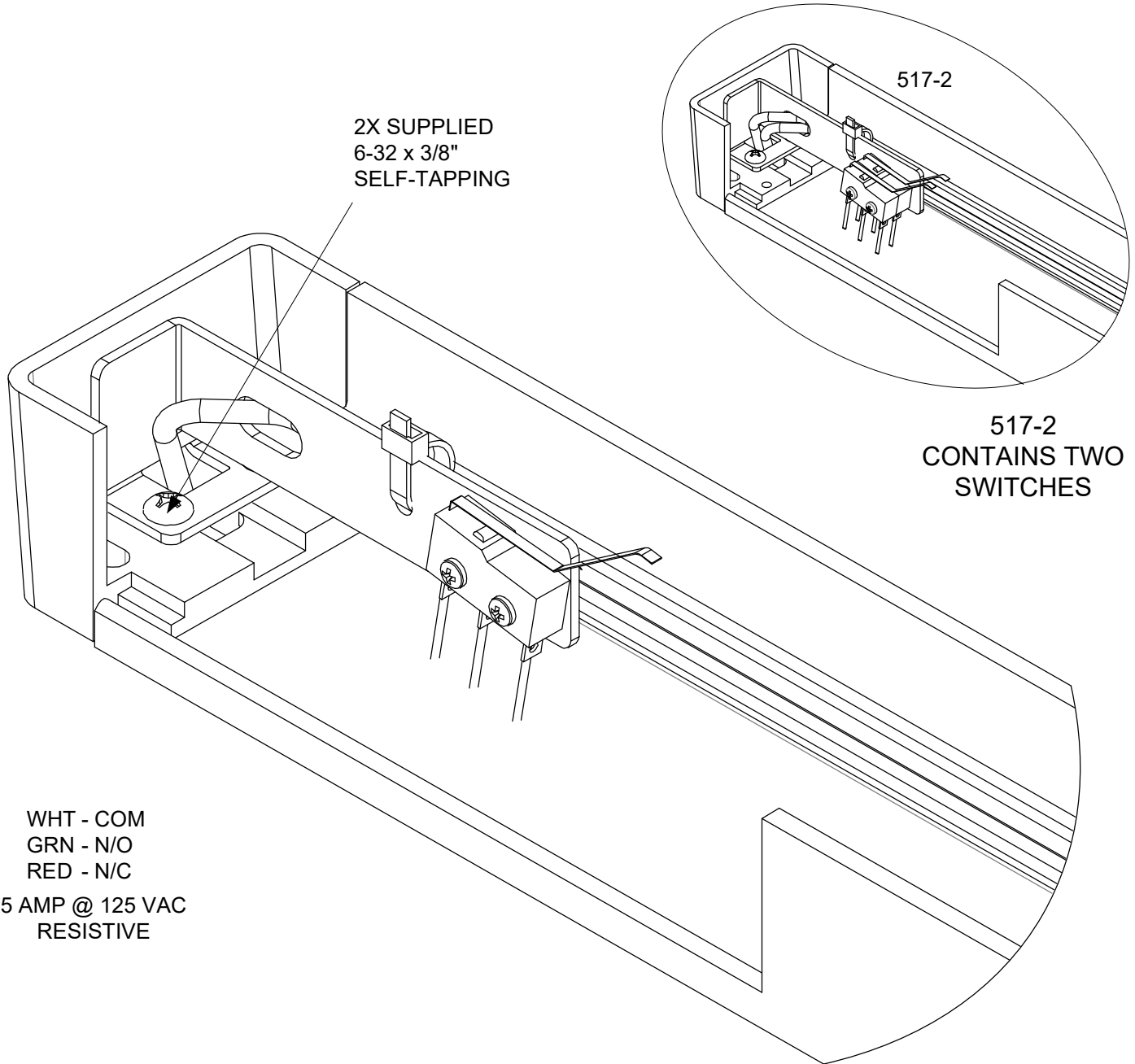

2X SUPPLIED
6-32 x 3/8"
SELF-TAPPING

517-2

517-2
CONTAINS TWO
SWITCHES

WHT - COM
GRN - N/O
RED - N/C
5 AMP @ 125 VAC
RESISTIVE