



Gate EMLock® 1570 Series

Electromagnetic Gate Locks Magnetic Bond Sensor Standard

SDC's Gate EMLock® provides 1200lbs of holding force and enables the access and egress control of pedestrian and vehicle gates. Access controls such as card readers, digital keypads and remote control stations provide gate and lock control.

Gate EMLocks are compatible with manual and automatic, swinging and sliding, tubular and iron gates. The floating armature design compensates for gate misalignment with the electromagnet.



Weatherized

SDC Gate EMLocks are totally sealed in an epoxy filled stainless steel case. A threaded conduit fitting ensures weather resistant protection of the wiring.

Application

With no moving parts to bind or wear, the Gate EMLock® is inherently failsafe and will unlock automatically during a power outage. For security applications, the SDC 600 series power supplies with battery backup capability, provide continuous operation for up to 35 hours with just two 12VDC, 7 Amp Hour batteries.

Features

- Stainless Steel Case
- Epoxy filled for weather resistance
- Threaded conduit fitting
- Built-in voltage kickback protection
- Low power consumption
- Built-in bond sensor (BAS)

Ordering Information

Model	
1575U	Standard mounting with magnetic bond sensor
1576U	Face drilled with magnetic bond sensor
Options	
1576-BK	Mounting "L" bracket for 1576
1576-MP	Mounting plate for 1576
1576-ZB	Armature "Z" bracket for 1576
1576-AB	Armature angle bracket for 1576
BR64	Full wave bridge rectifier for AC operation

Specifications

Electrical Specifications

Holding Force 1200lbs

Voltage Input: 450mA @ 12VDC
225mA @ 24VDC

Bond Sensor

Output: 125mA @ 12/24VDC

Wire Leads: 24 AWG, 3ft. long

Conduit Fitting: 1/2" Length, 3/4" outside thread,
1/2" inside thread

Mechanical Specifications

Lock: 8-21/32"L x 2-1/2"H x 1-39/64"T

Armature: 7-9/32"L x 2-13/32"H x 5/8"T

Case: Stainless steel

SECURITY DOOR CONTROLS

www.SDCsecurity.com Email: service@SDCsecurity.com

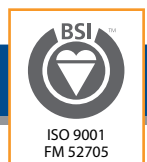

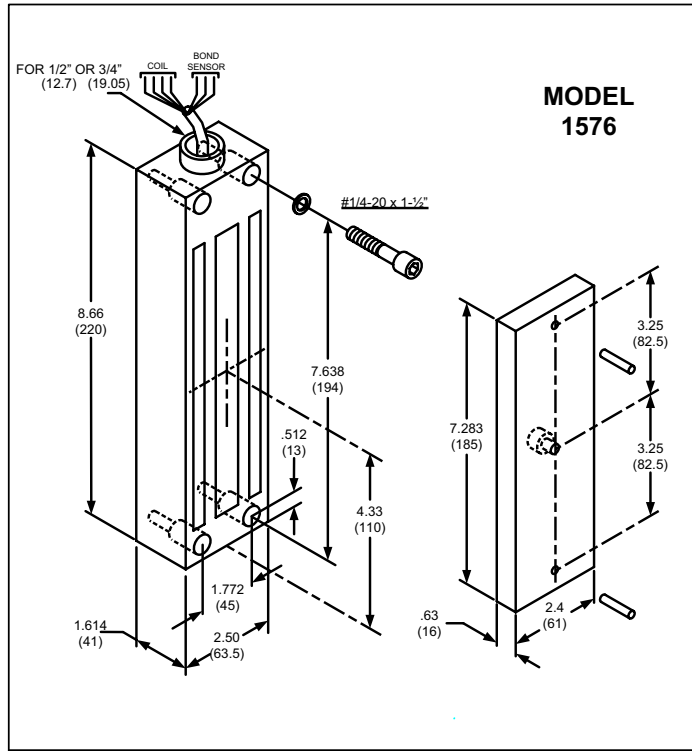
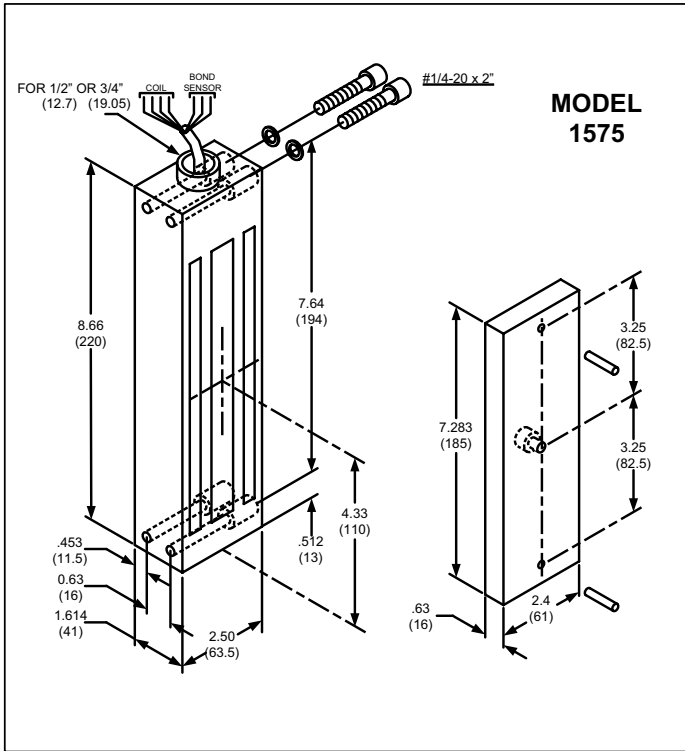

MAGNETIC BOND SENSOR WIRING		
Wire Color	Contact	Description
Yellow	N/O	Good Bond
Green	Common	Common
Orange	N/C	No/Poor Bond

1576-MP

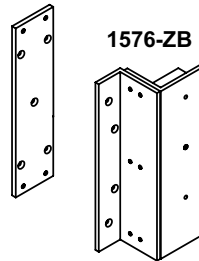

1576-AB

