

# **SDC** SECURITY DOOR CONTROLS

801 Avenida Acaso, Camarillo, Ca. 93041 • (805) 494-0622 • Fax: (805) 494-8861  
www.sdcsecurity.com • E-mail: service@sdsecurity.com

## INSTALLATION INSTRUCTIONS Model 930 EntryCheck™

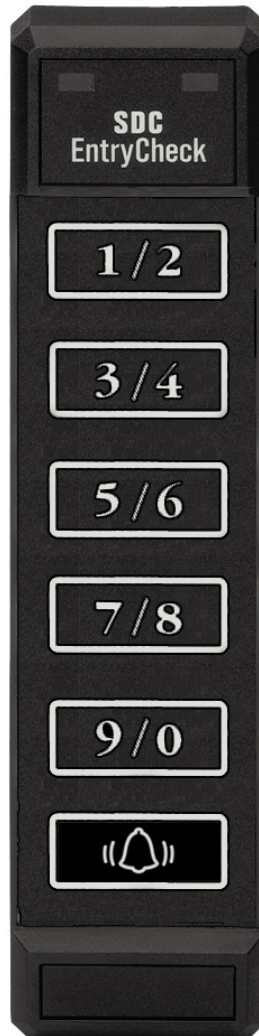

The 930 EntryCheck™ is an easy to program, easy to use, stand alone, self-contained system with features suitable for basic access control requirements. Providing either a voltage output or dry contact closure, the 930 is designed to control any fail-safe or fail-secure electric locking device.

The 930 features one master code and five user codes. One relay output is available to provide a variety of access control configurations including single door access control, Gate/Garage Door control or other electronic equipment control. The 930 also provides two ¼ Amp grounding outputs for a CCTV/Light Controller and Doorbell operation.

## Table of Contents

<b>SYSTEM SPECIFICATIONS</b>	<b>3</b>
<b>INPUT REQUIREMENTS</b>	<b>4</b>
<b>OUTPUT CAPABILITIES</b>	<b>4</b>
<b>OPERATING TEMPERATURES</b>	<b>4</b>
<b>PREPARING FOR INSTALLATION</b>	<b>5</b>
SYSTEM COMPONENTS	5
<b>THE INSTALLATION PROCEDURE</b>	<b>5</b>
REQUIRED TOOLS	5
PREPARE THE KEYPAD FOR INSTALLATION	5
INSTALL THE WIRING CABLE	6
CONNECT THE 930 EntryCheck	6
PREPARE THE DOOR FOR THE ELECTRIC STRIKE	6
CONNECTING THE LOCKING DEVICE	6
<b>SYSTEM HARDWARE SETUP</b>	<b>6</b>
REMOTE BY-PASS	6
ANTI-TAILGATING	7
SETTING RELAY OPTIONS	7
TAMPER ALARM LOCKOUT	7
<b>SYSTEM PROGRAMMING</b>	<b>8</b>
OVERVIEW OF SYSTEM CODE PROGRAMMING	8
OVERVIEW OF THE MASTER CODE	8
PROGRAMMING THE MASTER CODE	8
OVERVIEW OF USER CODES	9
PROGRAMMING USER CODES	9
DELETING A USER	9
PROGRAMMING THE DOOR OPEN TIME	9
<b>TROUBLESHOOTING</b>	<b>10</b>
<b>APPENDIX A – CIRCUIT BOARD LAYOUT</b>	<b>11</b>
<b>APPENDIX B – TYPICAL WIRING DIAGRAMS</b>	<b>12</b>

## SYSTEM SPECIFICATIONS

<b>Input Requirements:</b>	12 to 24V AC/DC
<b>Standby Current Draw:</b>	< 10 mA
<b>Maximum Current Draw:</b>	100 mA (Using keypad illumination)
<b>Main Output:</b>	One SPDT Relay (2 Amps at 24V max)
<b>CCTV/Light Output:</b>	<ul style="list-style-type: none"> <li>• Voltage or Dry Contact</li> <li>• Fail Safe or Fail Secure Lock</li> </ul>
<b>Doorbell Output:</b>	Two ¼ A Grounding Outputs <ul style="list-style-type: none"> <li>• First key press: 10 sec Output</li> <li>• Press the  : 1 sec Output</li> </ul>
<b>Programmable Output (Door Open Time)</b>	1 to 120 seconds Default → 5 seconds
<b>Latching:</b>	Manual (Toggle On/Off)
<b># of User Codes:</b>	6 Codes (1 Master, 5 User)
<b>Code Length:</b>	3 to 8 Digits
<b>Default Master Code:</b>	1-3-5-7-9
<b>Tamper Alarm:</b>	25 Incorrect Key Presses
<b>Code Protection:</b>	Non-Volatile Memory
<b>Keypad Operating Environment:</b>	-40° C to + 70° C (-40° F to + 160° F) 100 % Relative Humidity
<b>Keypad Dimensions:</b>	7 1/8" x 1 3/4" x 3/4"

## INPUT REQUIREMENTS

The 930 EntryCheck™ accepts 12 or 24 Volts AC/DC. System current draw (maximum):  
Standby: 10mA at 12/24 Volts  
During Operation: 100 mA max

**IMPORTANT:** When powering the 930 with 12 or 24 VAC the maximum output current allowed from the Red DC output wire is 1/2 Amp. Check the specifications of your locking device. Make sure that the locking device draws less than 1/2 Amp. For locking devices that draw more current, a separate power supply is required. (See Appendix B)

**Note:** If connecting DC, make the connections to the Red and Black wires instead of the Gray and White wires (see Appendix A – Page 11). Make sure the polarity is correct.

## OUTPUT CAPABILITIES

The 930 EntryCheck™ provides one SPDT dry contact relay (rated at 2 Amps at 24 VAC). The relay can be configured for one of the following options:

- Voltage Output – Fail Safe or Fail Secure Locking Device
- Dry Contact Output – Control a Gate Operator/Garage Door

Two auxiliary 1/4 A grounding outputs are available to drive external relays. These can be configured for:

- CCTV/Light Controller or other – First key press triggers a 10 second output.
- Doorbell or other – Press the  symbol to trigger a 1 second output.

## OPERATING TEMPERATURES

Operating temperatures can range from -40°C to +70°C (-40°F to 160°F).

## PREPARING FOR INSTALLATION

### SYSTEM COMPONENTS

There are four primary components to be installed:

1. The 930 EntryCheck™ should be mounted on the wall adjacent to the door. It should be on the same side as the door strike and about 4 feet above the floor.
2. The Wiring Harness connects the keypad to a power supply, locking device and auxiliary relays. Included with the system is a 12 inch wiring harness. Splice additional wire to this harness to connect to the power supply, locking device, etc. (See Appendix A – Typical System Wiring.)
3. The Electric Strike/Other Locking Device (not included) connects to the 930's Relay output via the strike wires. (See Appendix A - Typical System Wiring)
4. The Power Supply (not included) should meet the following specifications:
  - 12 or 24 Volts AC/DC
  - 100 mA min. (250 mA min. preferred)

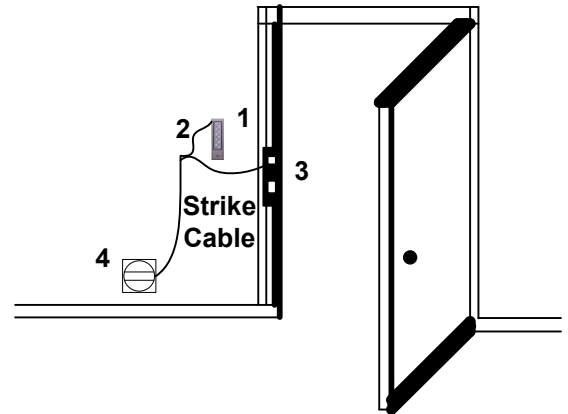

**Typical Installation**

## THE INSTALLATION PROCEDURE

### REQUIRED TOOLS

You will need the following tools:

- Medium Phillips screwdriver
- Drill
- $\frac{7}{8}$ " or 1" (25mm) drill bit
- $\frac{3}{16}$ " (6mm) drill bit

### PREPARE FOR INSTALLATION

There are different procedures for mounting the 930 SERIES depending on the type of composition of the mounting surface. A template is included to assist with installation.

#### Mounting Instructions

The 930 SERIES is designed for mullion mount applications. It can also be mounted on a wall, pedestal or any flat surface of at least  $1\frac{3}{4}$ " by 7". The composition of the mounting surface will determine the fastening method required:

1. Select a flat surface ( $1\frac{3}{4}$ " by 7") near the door where you wish to install the keypad.
2. Using the template, mark location of holes. Typical Installation
3. Drill the large hole using the  $\frac{7}{8}$ " or 1" (25mm) drill bit.
4. Place the connector on the back of the keypad in the large hole to verify that the mounting holes are aligned. Make adjustments if necessary.
5. Drill mounting holes in accordance with fastening method used. If mounting to wood, drill small pilot holes and use #8 flat head wood screws provided. Do NOT mount the keypad at this time.
6. Proceed to Install the Wiring Cable.

## INSTALL THE WIRING CABLE

1. Drill a hole in the inside wall or ceiling where you want the cable to come through.
2. Splice added cable length to the wires you will be using (Power, locking device, etc. - See Typical System Wiring). Then pull the cable through the hole so the connector end goes to the keypad. Route it so there is minimal cable at the keypad.

## CONNECT THE 930 EntryCheck™

1. Attach the wiring connector to the Keypad.
2. Do NOT mount the Keypad until the system is programmed and tested.

## PREPARE THE DOOR FOR THE ELECTRIC STRIKE

Follow these instructions only if you are using an electric strike to unlock the door. If you are using the relay to activate a garage door, automatic gate, etc., skip this section. The new electric strike should be checked to verify compatibility with existing door hardware prior to installation.

1. Remove existing strike.
2. Follow directions included with the strike for preparing the doorjamb.
3. Do NOT mount the strike at this time.

## CONNECTING THE LOCKING DEVICE

Connect the electric locking device to the wire harness as outlined in the Typical System Wiring (Appendix A – Page 11) and Typical Output Wiring (Appendix B – Page 13). Any 2 conductor, 22 gauge wire can be used to connect the Keypad to the Locking Device. Included in the spare parts kit is a MOV (Metal Oxide Varistor). The function of the MOV is to absorb any inductive kickback from the locking device, protecting the Keypad circuit board.

\* **IMPORTANT:** If switching voltages higher than 24V, you must use an external relay. The 930's built-in relay is capable of switching up to 24V.

## SYSTEM HARDWARE SETUP

### REMOTE BY-PASS

In some cases, it may be necessary to control the door from a remote area such as a security station or reception desk. The 930 EntryCheck™ provides for a Remote By-Pass (Exit Switch) or Keypad override. This can be accomplished by connecting a normally open switch from the VIOLET "Remote Bypass" wire to the BLACK wire (See Appendix A – Page 11). When the Remote By-Pass switch is depressed, the contact bypasses the Keypad and activates the relay for the same time length as the programmed Door Open Time (See Programming Door Open Time – Page 10).

## ANTI-TAILGATING

Some security applications require stricter door monitoring. Anti-tailgating can be controlled by installing a normally closed door monitor switch to the BROWN “Door Monitor” wire and the BLACK wire on the wire harness (See Appendix A – Page 11). This switch may be the output of a latch monitor switch, a monitor maglock or an alarm switch that senses door movement. When this switch opens, it relocks the door immediately.

\* **IMPORTANT:** If you wish to use door monitor switch, you must also cut the BROWN “Door Monitor” wire loop on the back of the Keypad. (See Appendix A – Page 11).

## KEYPAD ILLUMINATION

Designed for areas with low ambient lighting, the 930 EntryCheck™ provides nighttime illumination. Keypad illumination is “ON” by default. This option can be turned “OFF” by cutting the BLUE “Illum” wire loop on the back of the Keypad.

\* **IMPORTANT:** If switching voltages higher than 24V, you must use an external relay. The 930’s built-in relay is capable of switching up to 24V. (See Appendix A – Page 11)

## SETTING OUTPUT OPTIONS

The 930 EntryCheck™ provides options for configuring the relay output as well as the ¼ Amp grounding outputs. These options include Voltage vs. Dry Contact Output and Latching Authorization for the main output.

Voltage vs. Dry Contact – The 930’s relay can provide either a voltage or dry contact output. By default, the “DC+” Jumper on the back of the Keypad is configured for voltage output of up to 24V max. (See Appendix A – Page 11) This jumper feeds the +DC out directly to the relay COM contact. (This is the same as connecting the RED wire to the GREEN wire). For a dry contact output (garage door/gate operator), remove the DC+ jumper.

Latching – Latching provides manual control of the locking device. On the 930, only User Codes 1 & 2 have the ability to latch. By default, latching is “ENABLED” for these users. To disable Latching, cut the “GREEN Latch” wire loop on the back of the Keypad. (Appendix A – Page 11). When Latching is ENABLED, User Code 1 or User Code 2 followed by “7” will latch the relay “ON”. Either code followed by “7” will latch the relay back “OFF”.

**Note:** The Master Code and User Codes 3,4 and 5 do NOT have the ability to Latch.

¼ Amp Grounding Output Options:

1. CCTV/Light Output (10 sec. output): By connecting an external relay to the 930’s BLUE “CCTV” wire (See Appendix A – Page 11), any key press on the Keypad triggers a 10 second output.

2. Doorbell Operation (1 sec output): By connecting an external relay to the 930’s ¼ Amp grounding output – “TAN Doorbell” wire (See Appendix A – Page 11), pressing  at the Keypad triggers a 1 second output.

**Note:** If using either option, an MOV (Metal Oxide Varistor) should be installed to prevent inductive kickback.

## TAMPER ALARM LOCKOUT

A person attempting to gain entry by guessing the code and pushing 25 wrong digits will cause the 930 EntryCheck™ to go into tamper alarm mode. The Keypad will beep constantly for 30 seconds during which time the door will remain locked and no keypad functions can be performed.

# SYSTEM PROGRAMMING

## OVERVIEW OF SYSTEM CODE PROGRAMMING

There are TWO levels of codes for the 930 EntryCheck™ system.

1. The Master Code (used by owner/management to open the door and to program User Codes)
2. User Codes (used by guests/personnel to open the door)

**IMPORTANT:** Notes to remember before programming:

1. All codes must be 3 to 8 digits.
2. All codes must be different from each other.

**Note:** The 930 has two digits on each pad.

The system reads these numbers as the same. For example: 1-3-5-7-9 is the same as 2-4-6-8-0.

3. Do not program codes, which are part of other codes. 

1 / 2
-------

  
Example: User Code 1 → 1-2-3-4 and User Code 2 → 1-2-3

4. During programming, the system resets after 5 seconds if a number is not entered. Do not let more than 5 seconds elapse between entries or the system will reset and you will have to start over.

## OVERVIEW OF THE MASTER CODE

Knowledge of the Master Code is the highest privilege granted to a user of the 930 EntryCheck™ system. There is only one master code, which is used to program each of the 5 User Codes. The factory default Master Code, “1-3-5-7-9”, can be used for initial programming but should be changed to a unique code.

## PROGRAMMING THE MASTER CODE

**To Program/Change the Master Code:**

1. Select a 3 to 8 digit code that will be used for the Master Code. \_\_\_\_\_
2. Enter the old Master Code (default is 1-3-5-7-9) followed by the  symbol on the keypad. (The Keypad will beep rapidly 4 times \*) Proceed to step 5.
3. If you do NOT know the Master Code, locate the PINK Program wire on the harness. (As an alternative, you can momentarily short the two “PGM” pins on the back of the Keypad. This will take you to step 5)
4. Touch the PINK Program wire to the BLACK wire for one second (The Keypad will beep rapidly 4 times)\*
5. At the Keypad, enter 1-1-1-9 to open the memory (you will hear three rapid beeps) and immediately enter your new Master code.

(Do NOT let more than five seconds elapse between entries or the system will reset and you will have to start over.)

6. After entering your new Master Code, wait five seconds for the 3 reset beeps.

\*Once in Programming Mode, you have 2 minutes to begin programming. After 2 minutes, the system resets to Normal operation.

## OVERVIEW OF USER CODES

There are a total of 5 User codes that can be programmed into the 930 EntryCheck™. User Codes can vary in length from 3 to 8 digits. Each User Code is programmed into one of 5 User Locations.

These Locations are as follows:

<u>User #</u>		<u>User Location</u>
User Code 1	————→	1-1-1
User Code 2	————→	1-1-3
User Code 3	————→	1-1-5
User Code 4	————→	1-1-7
User Code 5	————→	1-1-9

Once a User Code has been programmed into a User Location, the User Code can be easily changed or deleted from the system (see Programming User Codes).

## PROGRAMMING USER CODES

### To Program a New User Code/Change an Existing User Code:

1. Choose a new 3 to 8 digit code that will be used for this User Code. \_\_\_\_\_
2. Decide which User Location to place this User Code (see Overview of User Codes)
3. Enter the Master Code, followed by the User Location (you will hear three rapid beeps) and immediately enter the new User Code. (Do not let more than five seconds elapse between entries or the system will reset!!!)

Example: (Master Code: 1-3-5-7-9) (User Location: 1-1-1) (User Code: 1-3-3-5)  
This programs the code 1-3-3-5 into User Location #1.

4. After entering your new code, wait five seconds for the 3 reset beeps.

### To Delete a User Code

1. Enter Master Code, followed by the User Location of the User Code you want to delete (you will hear 3 rapid beeps).

Example: (Master Code: 1-3-5-7-9) (User Location: 1-1-5)  
This deletes the User Location #3 programmed code.

2. Wait five seconds for the 3 reset beeps (Do NOT enter any digits until you hear 3 reset beeps)

## PROGRAMMING THE DOOR OPEN TIME Default is 5 seconds

1. First determine the length of time you wish to program as the Door Open Time. This is the length of time the door will remain open after a valid Code has been entered.

**Note:** For controlling a garage door or electric gate, you will need to set the door open time to 1 second and remove the “DC +” Jumper on back of keypad.

2. Enter the Master Code (default is 1-3-5-7-9) followed by the  symbol on the keypad. (The Keypad will beep rapidly 4 times\*). Proceed to step 5.
3. If you do NOT know the Master Code, locate the PINK Program wire on the harness. (As an alternative, you can momentarily short the two “PGM” pins on the back of the Keypad. This will take you to step 5)
4. Touch the PINK Program wire to the BLACK wire for one second (The Keypad will beep rapidly 4 times)\*
5. At the Keypad, enter 1-1-1-7 to open the memory (you will hear three rapid beeps) and enter a combination of “5’s” (for every five second increment) and “1’s” (for every one second increment) that equal your desired Door Open Time. Each valid key press (a “1” or a “5”) will generate a double beep.

Example: (User Location: 1-1-1-7) (Time: 5-5-5-1-1) ———→ 17 seconds

6. After entering your Door Open Time, wait five seconds for the 3 reset beeps.

**Notes:** \* Once in Programming Mode, you have 2 minutes to begin programming. You will hear a double beep with each valid key press. Once you begin entering the combination of 1’s and 5’s do not let more than five seconds elapse between entries or the system will reset. Maximum Door Open Time is **120 seconds**.

## TROUBLESHOOTING

These are a few troubleshooting suggestions to help assist with any problems you may experience. If the problem continues or is not answered here, please call Security Door Controls (SDC) technical support at 1-800- 413-8783. You may visit SDC on the web at [sdcsecurity.com](http://sdcsecurity.com) or send question via email: [service@sdcsecurity.com](mailto:service@sdcsecurity.com).

### CHANGED OR DELETED A CODE AND THE OLD CODE STILL WORKS

Remember the 930 EntryCheck™ has a total of 6 User Codes. Make sure you've changed the desired code. If you changed the Master Code, the other User Codes will still work. If in doubt, it is recommended you reprogram the master code and delete all 5 user codes. Then program any new user codes.

### KEYPAD BEEPS BUT THE DOOR DOES NOT UNLOCK

If the Keypad beeps but an authorized code does not open/unlock the door, there is an easy test to check the wiring hookup to the locking device. Locate the VIOLET "Remote" wire and momentarily short to the BLACK wire. This will activate the output (same as if you enter a valid programmed code at the Keypad). If this test does not activate the lock, you may have wired the lock incorrectly to the 930 (See Appendix A – Typical System Wiring.) If this test does activate the output (you should hear the relay click and the locking device should unlock), then the problem may be:

- **Programming** - If the unit has just been installed, the problem is most likely with programming the system codes. Review Overview and Programming of User Codes again remembering that all six codes have to be different from each. It is also important not to let more than 5 seconds elapse between button presses or the system will reset and you will have to start over.
- **Code Loss** - (Existing installations) There are typically two reasons for code loss: static or inductive kickback. There is no way to determine if the system has been affected by either of these, however, you can reprogram the system codes as described in User Code Programming. It is very important the system is properly grounded otherwise static and code loss may be an ongoing problem.

### KEYPAD IS COMPLETELY DEAD

Interrupted Power - First check your power supply to see that power has not been cut off. Using a voltmeter, check the incoming voltage on the GRAY and WHITE wires (12-24V AC). If using 12-24V DC, check DC voltage between the RED and BLACK wires. If the voltage reads low, the electric locking device may be drawing too much current. To test, remove the wires to the device and recheck the voltage. If the voltage now reads normal, check the current draw of the locking device and make sure it falls within the system specifications (see Input Requirements).

### KEYPAD BEEPS ALL BY ITSELF

Random Beeping – Possible low voltage or bad power supply. Also check EARTH ground.

## APPENDIX A – TYPICAL SYSTEM WIRING

**Wiring notes:**

- 1) The 930 EntryCheck™ is designed to control a 12 or 24V locking device. To control any voltage higher than 24V, you must switch an external relay.
- 2) To disable Latching Capability, cut the Green wire loop.
- 3) To disable Illumination, cut the Blue wire loop.
- 4) If connecting a Door Monitor switch, cut the BROWN wire loop.
- 5) For garage/gate operator, remove DC+ Jumper and set Door Open Time to 1 second.
- 6) To initiate programming, momentarily short the PGM pins or short PINK wire to BLACK wire.
- 7) To prevent inductive kickback, install factory supplied MOV across wires to locking device (install as close to the lock as possible).

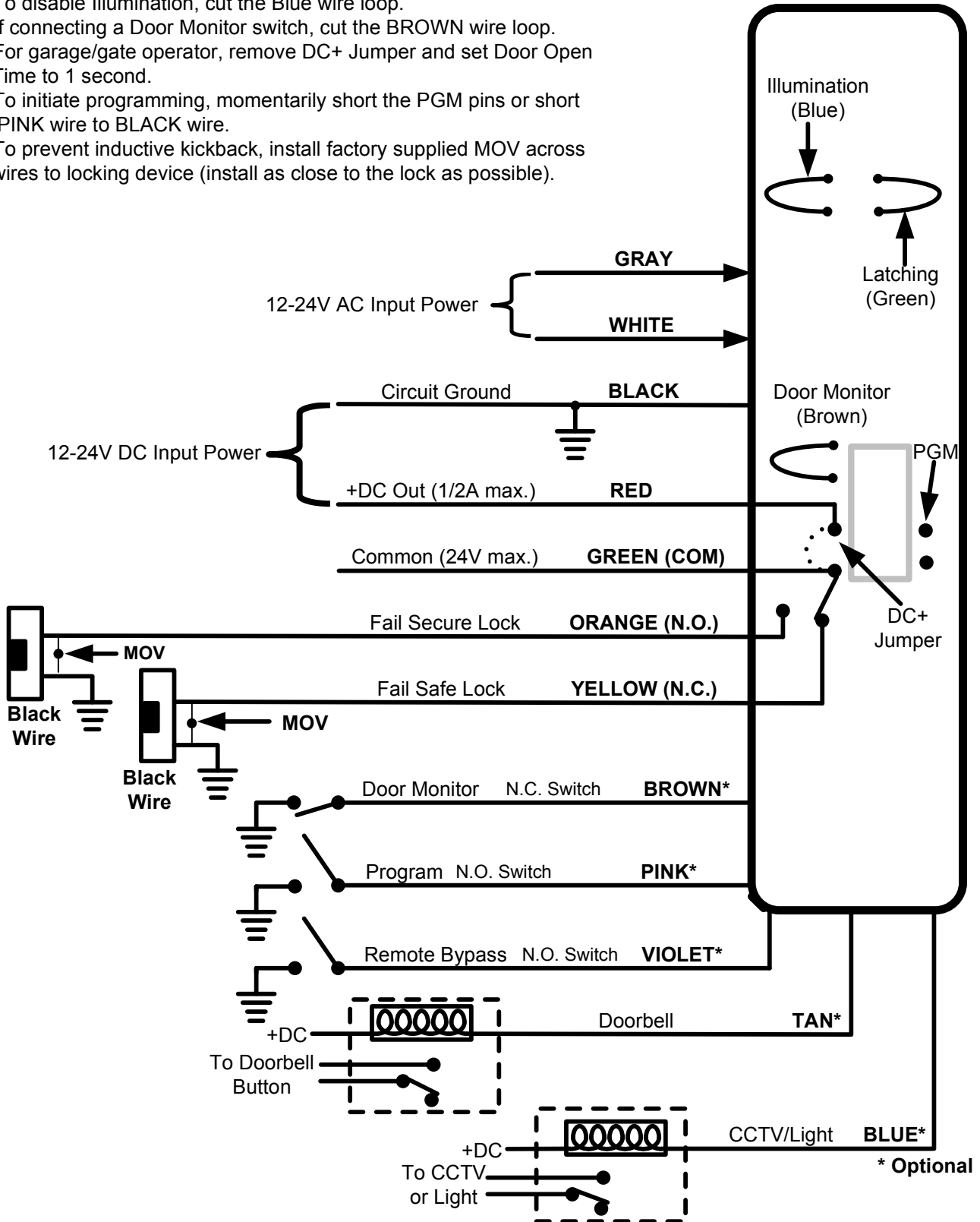

## APPENDIX B – TYPICAL OUTPUT WIRING

### Garage Door/Gate Operator Controlled by 930 EntryCheck

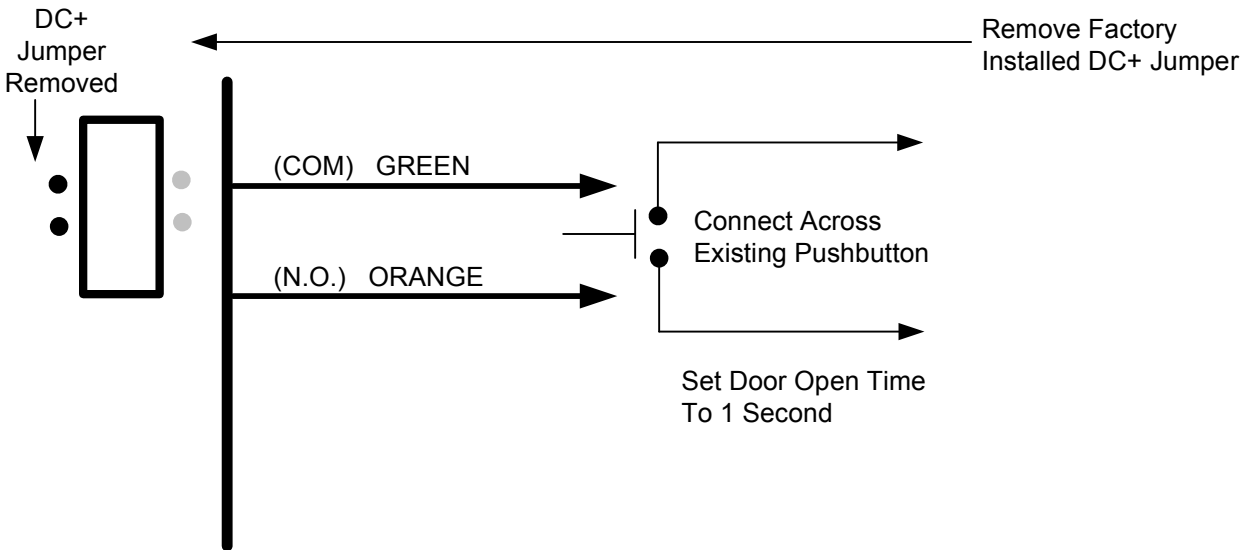

### Fail Safe or Fail Secure Lock Controlled by 930 Series and Powered by External Power Supply

