



SECURITY DOOR CONTROLS

3580 Willow Lane, Westlake Village, CA 91361-4921 • (805) 494-0622 • Fax: (805) 494-8861
www.sdcsecurity.com • E-mail: service@sdsecurity.com

INSTALLATION INSTRUCTIONS FS23M, 1090, 1190 SERIES

OVERHEAD INSTALLATION HORIZONTAL

1. Examine the top rail of the door for the most suitable location for the strike. Mark the door for the end of the strike closet to the lock stile, and make a corresponding mark on the header to line up with the first mark.
2. Locate center line of door thickness on the header and attach adhesive cut out template to header. Lining it up with marks, center punch the tab-mounting screw locations and counter-sink for #10 screw. Saw or rout out the cutout area.

SIDEJAMB INSTALLATION VERTICAL

3. Examine the lock stile jamb for the point nearest the center of the door height, with space available for the lock and strike. Mark the door stile horizontal for the top end of the strike and make a corresponding mark on the jamb.
4. Locate center line of door thickness on the jamb and attach adhesive cutout template to jamb, lining up the the top of the cutout with the horizontal mark on the jamb. Center punch the tab mounting screw locations and counter sink for #10 screw. Saw or rout the cutout 1-1/2" x 8".
5. Attach the mounting tabs inside.
6. (FS23M only) bore 5/16" hole for pilot lamp on inside face of frame as shown.
7. Attach power supply leads to lock leads as shown. Handle the lock carefully; do not hang it by the wire leads. Insert wires into the header cavity carefully so they do not interfere with proper locating of the lock in the cutout.
8. Insert lock. Horizontally, the bolt end is nearest the lock stile. Vertically, the bolt must be at the top end of the cutout. Secure with 10/32 machine screw.
9. Using strike for a template, mark screw hole location and drill holes for screws supplied. Mortise as required. Attach strike.
10. The automatic relock switch is set for 1/8" clearance between the top of the door and transom bar or head jamb. Any additional gap may be compensated for by loosening the lock nut and turning the switch assembly clockwise until proper adjustment is reached. Be sure to tighten lock nut when adjustment is satisfactory.

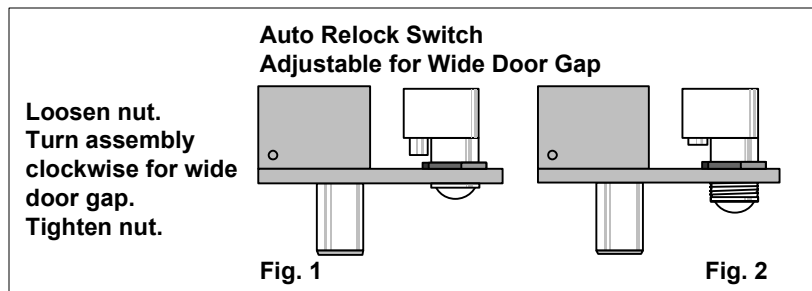

Easy Installation or Servicing

All Space Saver locks are easily installed in any existing entrance merely by mortising out a cutout, attaching the wiring, inserting the lock, and bolting it into position with two attaching tabs. Cutting studs is no longer a problem or expense.

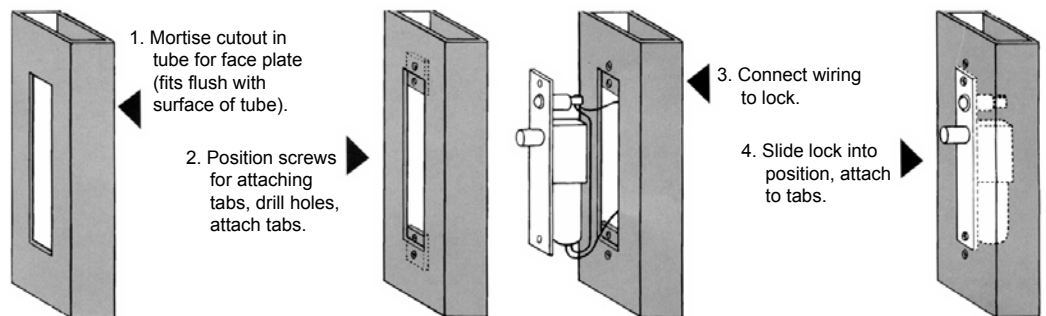

1190A

Face plate: 8" x 1-1/2" x 0.125"
(203.2mm x 38.1mm x 3.175mm)

I.D. Requirements: 8" x 1-1/2" x 1-1/2"
(203.2mm x 38.1mm x 38.1mm)

Solenoid: Continuous duty
Standard voltage: 24VDC @ .7 Amp

Strike: M-Mortise 4" x 1-1/2" x 0.125" (101.6mm x 38.1mm x 3.175mm)

Bolt: 3/4" (6.35mm) dia. S.S., 3/4" (6.35mm) throw

FOR 1190A ONLY:

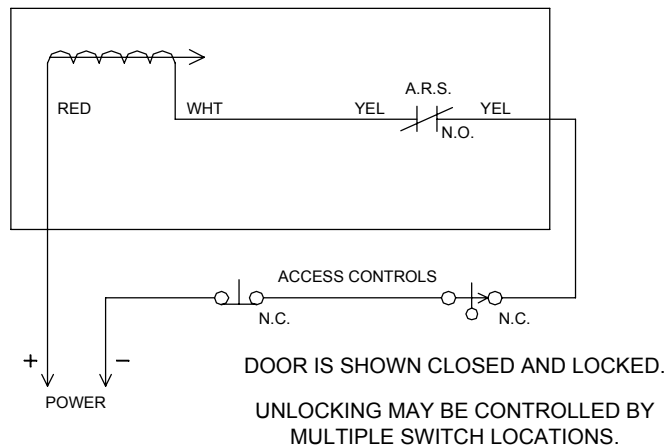

FS23M

Face plate: 8" x 1-1/2" x 1/8"
(203.2mm x 38.1mm x 3.175mm)

I.D. Requirements: 8" x 1-1/2" x 1-1/2"
(203.2mm x 38.1mm x 38.1mm)

Solenoid: Continuous duty
Dual Voltage:
12VDC @ .9 Amp
24VDC @ .45 Amp

Strike: M-Mortise 4" x 1-1/2" x 0.125" (101.6mm x 38.1mm x 3.175mm)
For wood 1-3/4" deep (44.45mm)

Bolt: 5/8" (15.88mm) dia. nylon with magnet insert, 5/8" (15.88mm) throw.
Red pilot lamp standard to indicate door locked.

FOR FS23M AND 1091A/1091ADC:

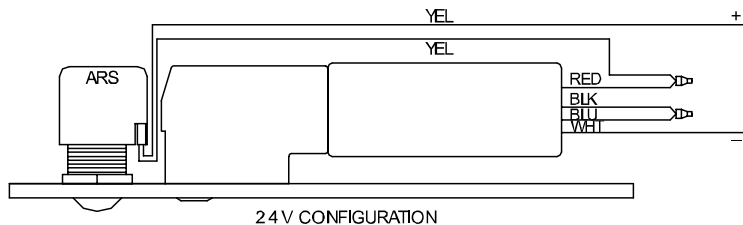
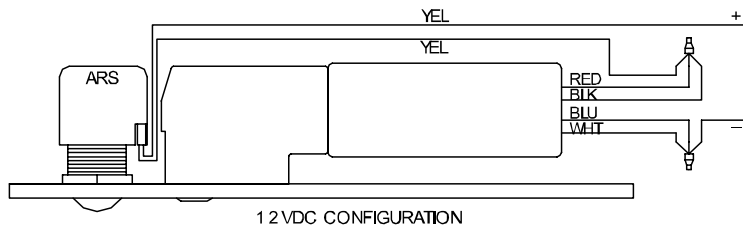

1091A/1091ADL (DEADLOCKING)

Face plate: 8" x 1-1/2" x 0.125" (35.1mm x 35.1mm x 3.175mm)
1091STA: 4-7/8" x 1-1/4" x 0.0937" ANSI
(123.53mm x 31.75mm x 2.28mm)

I.D. Req. 8" x 1-1/2" x 1-1/2"
(203.2mm x 38.1mm x 38.1mm)

Solenoid: Continuous duty
Dual Voltage:
12VDC @ .9 AMP
24VDC @ .45 AMP

Strike: M-Mortise 4" x 1-1/2" x 0.125" (101.6mm x 38.1mm x 44.45mm)

Bolt: 5/8" (15.88mm) dia. S.S., 3/4" (6.35mm) throw

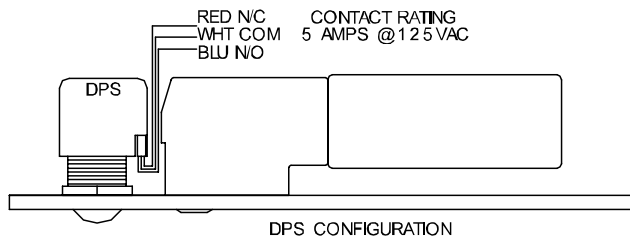

BOLT POSITION SENSOR (MAGNETIC)

No. 6 SPDT	Indicates bolt locked or unlocked	.25 Amp
------------	-----------------------------------	---------

DOOR POSITION SENSOR (MAGNETIC)

No.9 SPDT	Indicates door opened or closed	.25 Amp
-----------	---------------------------------	---------

DOOR POSITION SWITCH (MECHANICAL)

DPS SPDT	Indicates door opened or closed	5 Amp
----------	---------------------------------	-------

TROUBLE SHOOTING

Problem	Solution
Bolt does not project	Check voltage and alignment of strike.
Bolt projects but chatters	Voltage too low.
Bolt will not retract	Strike misaligned



SECURITY DOOR CONTROLS

3580 Willow Lane, Westlake Village, CA 91361-4921 • (805) 494-0622 • Fax: (805) 494-8861
www.sdcsecurity.com • E-mail: service@sdsecurity.com

1200 SERIES INSTALLATION INSTRUCTIONS

1. OVERHEAD INSTALLATION HORIZONTAL

Examine the top rail of the door for the most suitable location for the strike. Mark the door for the end of the strike closest to the lock stile, and make a corresponding mark on the header to line up with the first mark.

2. Locate centerline of door thickness on the header and attach adhesive cut-out template to header. Lining it up with marks, center punch the tab-mounting screw locations and counter-sink for #10 screw. Saw or rout out the cut-out area.

3. SIDE JAMB INSTALLATION VERTICAL

Examine the lock stile jamb for the point nearest the center of the door height, with space available for the lock and strike. Mark the door stile horizontal for the top end of the strike and make a corresponding mark on the jamb.

4. Locate center line of door thickness on the jamb and attach cut-out template to jamb, lining up the top of the cut-out with the horizontal mark on the jamb. Center punch the tab mounting screw locations and counter-sink for #10 screw. Saw or rout out the cut-out 1-1/2" X 8".
5. Attach the mounting tabs inside frame.
6. Attach power supply leads to lock leads as shown. Handle the lock carefully; do not hang it by the wire leads. Insert wires into the header cavity carefully so they do not interfere with proper locating of the lock in the cut-out.
7. Insert lock. Horizontally, the bolt end is nearest the lock stile. Vertically, the bolt must be at the *top end* of the cut-out. Secure with #10-32 machine screw.
8. Using strike for a template, mark screw hole location and drill holes for screws supplied. Mortise as required. Attach strike.
9. The automatic relock switch (A) is set for 1/8" clearance between the top of the door and the transom bar or head jamb. Any additional gap may be compensated for by loosening the lock nut and turning the assembly clockwise until proper adjustment is reached. Be sure to tighten lock nut when adjustment is satisfactory.

Easy installation or servicing

All Space Saver locks are easily installed in any existing entrance merely by mortising out a cut-out, attaching the wiring, inserting the lock, and bolting it into position with two attaching tabs. Cutting studs is no longer a problem or expense.

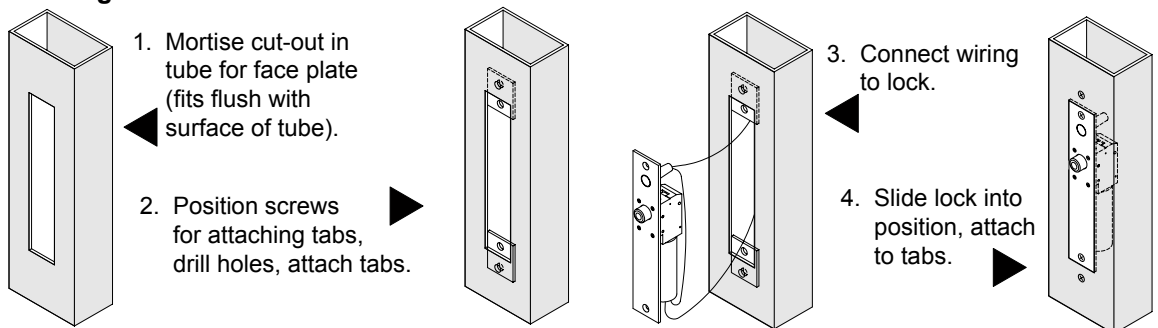

1200 SERIES

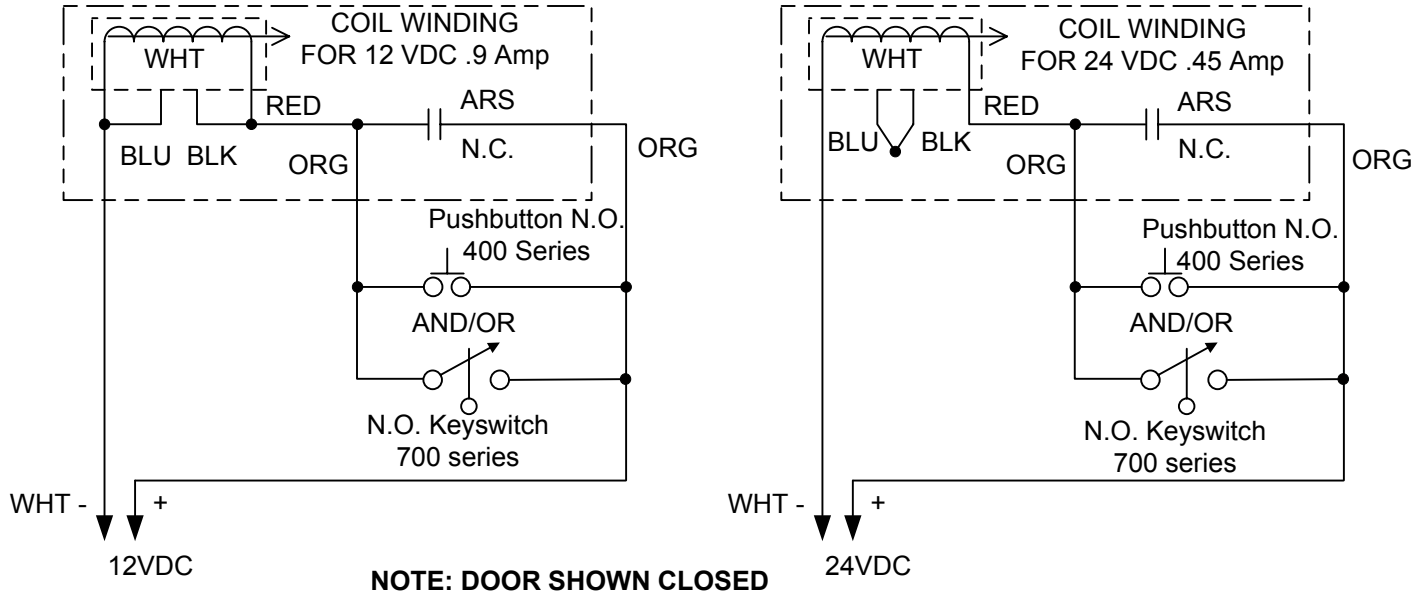

SPECIFICATIONS	MAGNETIC BOLT POSITION SENSORS						
Face plate: 8" x 1-1/2" x 1/8" for wood door frames: 8-1/2" x 1-1/2" x 1/8" I.D. Requirements: 1291A: 8" x 1-1/2" x 1-1/2" Solenoid: Continuous duty, fail secure type 500mA @ 24VDC 1 Amp @ 12VDC Strike: M-mortise 4" x 1-1/2" x 1/8" Bolt: 5/8" dia. stainless steel, 3/4" throw	-6 SPDT Indicates bolt locked or unlocked .25 amp						
	MAGNETIC DOOR POSITION SENSORS						
	-9 SPDT Indicates door open or closed .25 amp Mechanical Door Position Switch (DPS)						
	MECHANICAL DOOR POSITION SWITCH						
	DPS Indicated door position switch 3 amp @ 30V						
TROUBLE SHOOTING							
<table style="width: 100%; border-collapse: collapse;"> <thead> <tr> <th style="width: 50%; text-align: left;">Problem</th> <th style="width: 50%; text-align: left;">Solution</th> </tr> </thead> <tbody> <tr> <td>Bolt will not retract</td> <td>Check voltage and alignment of strike</td> </tr> <tr> <td>Bolt does not project</td> <td>Strike misaligned</td> </tr> </tbody> </table>	Problem	Solution	Bolt will not retract	Check voltage and alignment of strike	Bolt does not project	Strike misaligned	
Problem	Solution						
Bolt will not retract	Check voltage and alignment of strike						
Bolt does not project	Strike misaligned						

NOTE: Electrical boxes are available for most SDC mortise locks. We recommend electrical boxes whenever locks are installed in wood frames. (Request template).

