

# SDC Security Door Controls

801 Avenida Acaso, Camarillo, Ca. 93012 • (805) 494-0622 •  
 www.sdcsecurity.com • E-mail: service@sdsecurity.com

## INSTALLATION INSTRUCTIONS - MODEL UR2-4 UNIVERSAL DOOR CONTROLLER

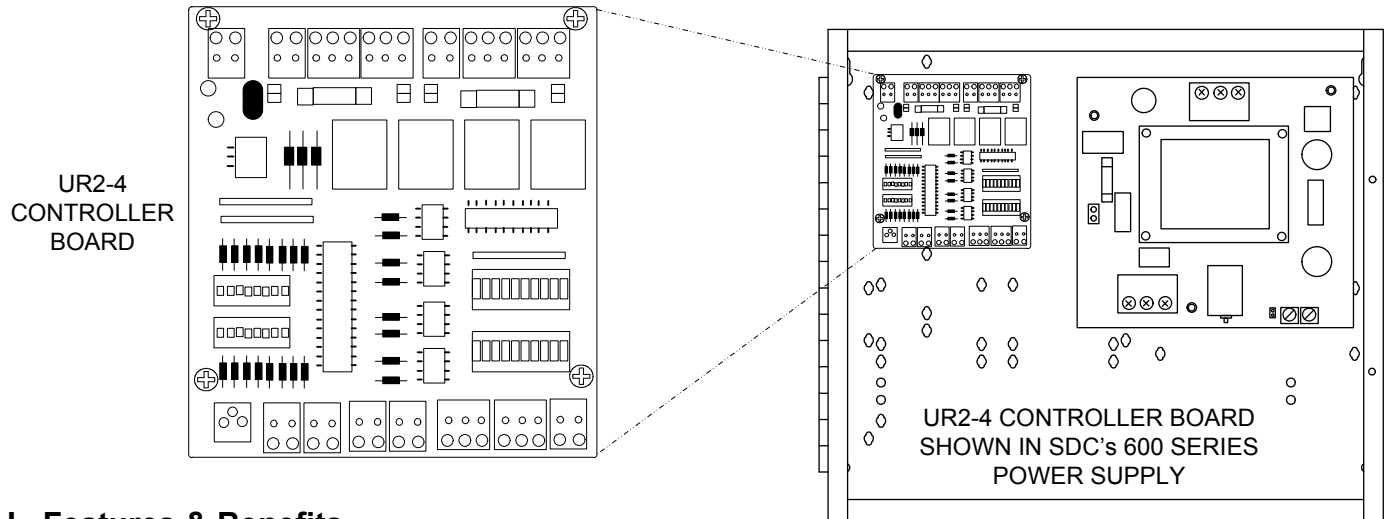

### I. Features & Benefits

- Microprocessor based relay controller that provides 7 different, field selectable application modes up to two door stations
- 3 field selectable Interlock (airlock) modes
- Field selectable Communicating (shared) bathroom mode
- Field selectable relay modes include:
  - Conventional Relay (CR)
  - Latching Relay (LR) – Pulse on, pulse off
  - Time Delay Relay (TD) – 1-65 seconds
  - Dual Function Relay (CR/LR, TD/LR, TD/CR, CR/CR)
- Each output relay is field selectable as a dry contact or a voltage output
- Centralized wiring for all locks, access controls, monitoring contacts, and peripheral equipment
- Onboard input/output status lights for easy troubleshooting
- 3 system control inputs: Lock All, Unlock All, System Lockout
- Emergency release input for fire panel interface
- Removable terminal blocks simplify installation
- 1 or 2 controllers may be installed in SDC 600 series power supplies

### II. Technical Specifications

<b>Input Voltage:</b>	12 or 24VDC +/- 10%
<b>Input Current:</b>	140 mA max. @ 12/24 VDC
<b>Relay Inputs:</b>	4-SPST, Dry, Optically Isolated All Normally Open or Normally Closed (field selectable)
<b>Auxiliary Inputs:</b>	4-SPST, Dry, Normally Open, Optically Isolated
<b>Relay Outputs:</b>	2 fused SPDT relays, 7A @ 30VDC 2 non-fused SPDT relays, 7A @ 30VDC Individually configurable as a dry contact or voltage output (field selectable)
<b>Dimensions:</b>	4.50" W x 5.00" H x 2" D (114.3 x 127 x 50.8 mm)

### III. UR2-4 Board Layout

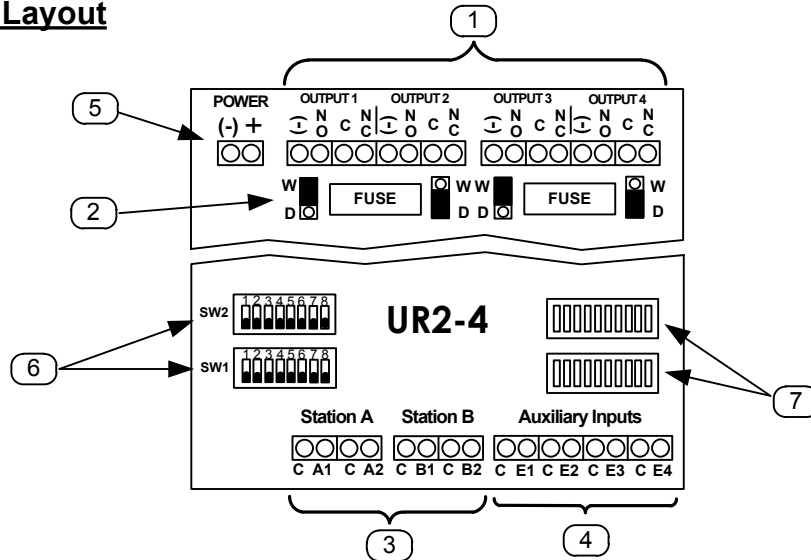

**1 RELAY OUTPUTS** – The UR2-4 provides four (4) individual SPDT relay outputs.

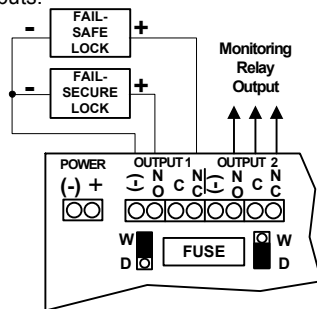

- Outputs 1 & 3 are fused. These outputs are typically used to power the door locking hardware.
- Outputs 2 & 4 are non-fused. These outputs are typically used as auxiliary (monitoring) relays. They may be used to power a remote status annunciator, or send a signal to a security panel.

**2 WET/DRY SELECTION JUMPER** – Each relay output may be individually configured as a wet (voltage) or dry output. Use the supplied jumpers to configure each relay.

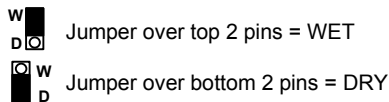

The relay output voltage will be the same as the UR2-4 input voltage (12 or 24 VDC).

**3 MAIN INPUTS** – The UR2-4 provides four (4) individual optically isolated inputs. The inputs must be connected to a dry switch.

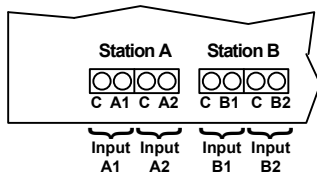

These inputs may be collectively configured as Normally Open or Normally Closed inputs.

**NOTE:** If Normally Closed inputs are selected, all unused inputs will need to be shorted.

**4 AUXILIARY INPUTS** – The UR2-4 provides four (4) individual dry, optically isolated auxiliary inputs.

**NOTE:** These input connections are optional and must be wired as Normally Open connections. The input will only be active when closed (shorted).

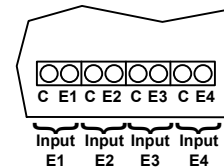

- **Input E1 – LOCK ALL** – When activated, this input will lock all the doors, until the input is deactivated. Main Inputs will be ignored.
- **Input E2 – UNLOCK ALL** – When activated, this input will unlock all the doors, until the input is deactivated. Main Inputs will be ignored.
- **Input E3 – LOCKOUT** – When activated, this input will cause all the lock outputs to remain in their current state, and ignore changes to the Main Inputs. Lock/Unlock All inputs will also be ignored.
- **Input E4 – EMERGENCY RELEASE (FIRE ALARM)** – When activated, this input will simultaneously release all fail-safe locks. Main Inputs, Lock/Unlock All inputs, and the Lockout input will be ignored.

**5 INPUT POWER CONNECTION** – The UR2-4 must be powered by a filtered and regulated 12 or 24VDC Power Supply. SDC 600 Series Power Supplies are designed to accommodate and interface with up to two (2) UR2-4 controllers.

**6 MODE CONFIGURATION DIP SWITCHES** – The UR2-4 utilizes two (2) 8-position dip switch modules for configuring the system operational modes. They are SW1 and SW2.



**7 STATUS LIGHTS** – The UR2-4 provides diagnostic lights to show the status of each individual input and output on the board.

If an output is active, its corresponding light will be ON.

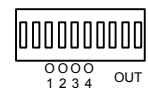

If an input is closed, its corresponding light will be ON.



## IV. Applications

For detailed wiring instructions and setup, select your specific application from the following available modes, and continue to the page number indicated next to the section title.

### Section V – 2-Door Interlock “A” Setup - Go To Pages 6 & 7

Both doors are normally closed and unlocked. Opening any door causes the other door to lock until the opened door returns to its normal state.

### Section VI – 2-Door Mantrap “B” Setup – Go To Pages 8 & 9

Both doors are normally closed and locked. Each door may be individually unlocked using the Access Control System or a remote release. Unlocking either door causes the other door to be incapable of being unlocked until the unlocked door returns to its normal state.

### Section VII – 2-Door Interlock “C” Setup – Go To Pages 10 & 11

Both doors are normally closed. One (1) door will be normally locked, and the other door will be normally unlocked.

Unlocking/opening the locked door will lock the unlocked door, until the unsecured door returns to its normal state. Opening the unlocked door will make the locked door incapable of being unlocked, until the opened door returns to its normal state.

### Section VIII – Dual Relay Control Mode – Go To Pages 12 & 13

In Dual Relay Control Mode, the UR2-4 operates as two (2) individually controlled relay stations. Each station provides:

- (1) Fused, SPDT lock output, wet or dry,
- (1) Non-fused, SPDT auxiliary (monitoring) output, wet or dry, and
- (2) Dry trigger inputs

**Station A Inputs control Outputs 1 & 2**  
**Station B Inputs control Outputs 3 & 4**

**Activating each station’s Input 1 OR Input 2 will trigger the corresponding lock output AND the auxiliary output simultaneously.**

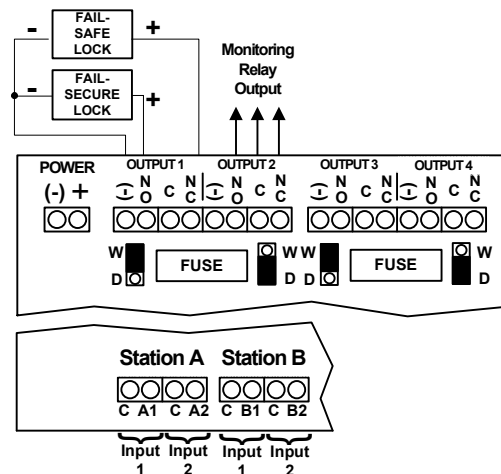

Input A1 may be configured to operate as a conventional relay or a time delayed relay.

Input A2 may be configured to operate as a conventional relay or a latching relay.

Input B1 may be configured to operate as a conventional relay or a time delayed relay.

Input B2 may be configured to operate as a conventional relay or a latching relay.

As a conventional relay (CR), the lock output relay is only activated while the trigger input is activated. Once the trigger input is released, the output relay returns to its resting state. The monitoring relay output follows the lock output relay.

As a time delayed relay (TD), the lock output relay is activated by the trigger input. Once the trigger input is released, the output remains activated for a specified period of time, as configured by the dip switches. The monitoring relay output follows the lock output relay.

As a latching relay (LR), the lock output relay is activated by the trigger Input. A single activation and release of the latching trigger input latches the lock output relay. The lock output relay remains latched until the latching trigger input is reactivated. The monitoring relay output relay follows the lock output relay.

## IV. Applications (Continued)

### Section IX – Single Relay Control Mode – Go To Pages 14 & 15

In Single Relay Control Mode, the UR2-4 operates as four (4) individually controlled relays.

Stations A1 & B1 each provide:

- (1) Fused, SPDT lock output, wet or dry and
- (1) Dry trigger input

Stations A2 & B2 each provide:

- (1) Non-fused, SPDT lock output, wet or dry and
- (1) Dry trigger input

Activating a single input will trigger a single output:

- Station A, Input 1 controls Output 1
- Station A, Input 2 controls Output 2
- Station B, Input 1 controls Output 3
- Station B, Input 2 controls Output 4

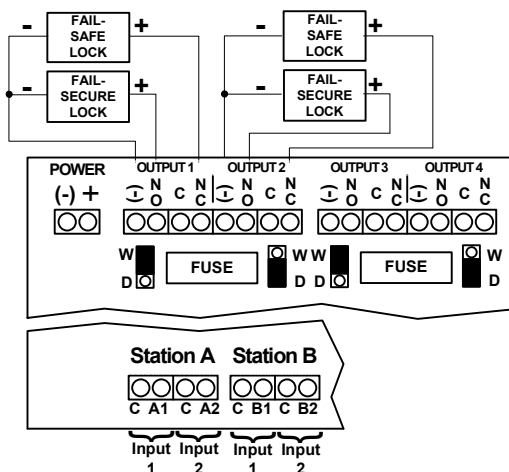

Each input may be individually configured to operate as a conventional relay or a time delayed relay.

Alternatively, each input may be individually configured to operate as a latching relay or a time delayed relay.

As a conventional relay (CR), the lock output relay is only activated while the trigger input is activated. Once the trigger input is released, the output relay returns to its resting state.

As a time delayed relay (TD), the lock output relay is activated by the trigger input. Once the trigger input is released, the output remains activated for a specified period of time, as configured by the dip switches.

As a latching relay (LR), the lock output relay is activated by the trigger input. A single activation and release of the latching trigger input latches the lock output relay. The lock output relay remains latched until the latching trigger input is reactivated.

### Section X – 2-Door Communicating (Shared) Bath System – Go to Page 16 & 17

Both doors are normally closed and unlocked.

#### System Activation:

Upon entering the bathroom and closing both doors, pressing an Activation button will lock both doors, and turn on the indicator lamps on the Activation and Emergency Unlock buttons, indicating the bathroom is occupied.

#### System Deactivation:

When using EMLocks®, pressing the Activation button a second time will unlock both doors and turn off all indicator lamps.

When using fail-safe electric strikes or electrified locksets, operating the inside lever to retract the latch on either door will unlock both doors and turn off all indicator lamps. Using a key override from the outside to enter either door will also reset the system and unlock both doors.

#### Emergency Override:

Emergency Unlock buttons located outside each bathroom door will immediately unlock its specified door and indicate its activation by causing the button's indicator lamp to flash. Pressing the Emergency Unlock button a second time will return the door to the locked state and the indicator lamp will return to a steady lighted state. Pressing the Activation button during an emergency override, will reset the system and unlock both doors.



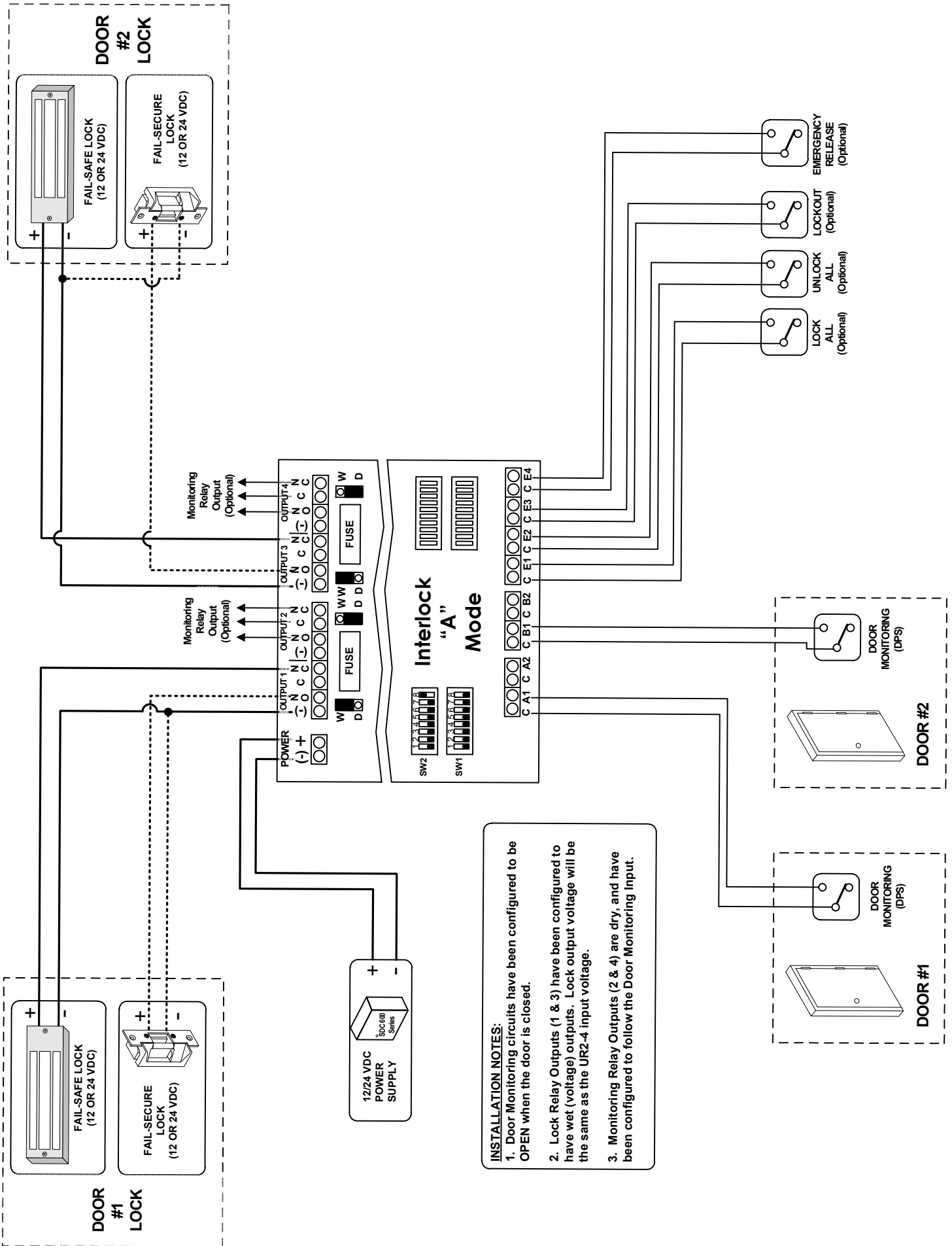

**INSTALLATION NOTES:**

1. Door Monitoring circuits have been configured to be OPEN when the door is closed.
2. Lock Relay Outputs (1 & 3) have been configured to have wet (voltage) outputs. Lock output voltage will be the same as the UR2-4 input voltage.
3. Monitoring Relay Outputs (2 & 4) are dry, and have been configured to follow the Door Monitoring Input.

## V. 2-Door Interlock "A" Setup

Follow the installation steps below before applying power to the UR2-4. Refer to the **INTERLOCK "A" MODE** wiring diagram on **Page 6**.

**NOTE:** It is assumed that the UR2-4 and locking hardware share the same power supply.

### Interlock "A" Standard Operation:

Both doors are normally closed and unlocked. Opening any door causes the other door to lock until the opened door returns to its normal state.

### Step 1 – Set Dip Switches

The dip switch settings below are an example of a typical Interlock A setup as shown on Page 6. Adjust the dip switch settings as needed.

SW1 -1 = OFF	Normally Unlocks Door #1. This switch <u>must</u> be set OFF for Interlock "A" Mode
SW1 -2 = OFF	Normally Unlocks Door #2. This switch <u>must</u> be set OFF for Interlock "A" Mode
SW1 -3 = OFF	
SW1 -4 = OFF	
SW1 -5 = OFF	
SW1 -6 = OFF	
SW1 -7 = OFF	
SW1 -8 = OFF	This switch <u>must</u> be set OFF for Interlock "A" Mode
SW2-1 = OFF	SW2-1 through 2-4 are not used for Interlock "A" Mode. These switches should all be set OFF.
SW2-2 = OFF	
SW2-3 = OFF	
SW2-4 = OFF	
SW2-5 = OFF	Sets the polarity of the Door Monitoring Inputs when the door is in the CLOSED position. {OFF = N/O; ON = N/C}
SW2-6 = OFF	This switch <u>must</u> be set OFF for Interlock "A" Mode.
SW2-7 = OFF	Sets the operation of all the Monitoring Relay Outputs. {OFF = Relay will follow the Door Monitoring Input; ON = Relay will follow the Lock Output Relay}
SW2-8 = ON	Switches the UR board between Interlock Mode or Control Mode. This switch <u>must</u> be set ON.

### Step 2 – Configure the Relay Outputs to be Wet (Voltage) or Dry.

Use the red WET/DRY Selection Jumpers to configure each output. Refer to Page 2 of this instruction for selection procedure.

On the typical Interlock A wiring diagram, the Lock Relays (Outputs 1 & 3) are configured to be wet outputs.

The Monitoring Relays (Outputs 2 & 4) are dry.

**NOTE:** It is recommended that any unused relays be configured as dry outputs.

### Step 3 – Terminate the Lock Power Wiring

Follow the typical Interlock A wiring diagram for fail-safe or fail-secure locks. Be careful to observe lock voltage polarity.

**NOTE:** All low voltage wiring shall be 18-gauge minimum. The minimum lock power wire gauge shall be determined by the SDC wire gauge chart. Signal wire shall be 22-gauge minimum.

### Step 4. Terminate the Door Monitoring Inputs

Connect the Door Monitoring Switches to Input terminals A1 & B1. This is a required connection.

Door Monitoring inputs (typically Door Position Switches), should be dry, Normally Open or Normally Closed switches, depending on the configuration of Dip Switch 2-5 (Step 1).

**NOTE:** Dip Switch 2-5 configures the normal state of the Door Monitoring input when the door is in a CLOSED position.

### Step 5. Terminate Auxiliary Inputs and Outputs (Optional)

**Auxiliary Inputs** – These inputs must be wired to dry, Normally Open switches. The input will only be active when closed (shorted). Refer to Page 2 for input descriptions.

**Monitoring Relay Outputs** – Each door station provides a non-fused, SPDT monitoring relay. This output may be used to signal a Security Panel or to activate a Remote Annunciator. The relay is configurable as a Wet or Dry output (Step 2). The relay activation will follow the Lock Relay or follow the Door Monitoring Input, depending on the configuration of Dip Switch 2-7 (Step 1).

### Step 6. Connect a 12 or 24VDC Power Source to the UR2-4 Controller.

Before applying power, verify that all the connections are securely terminated by gently pulling on each wire.

Terminate the voltage wiring to the Controller Power Input, as shown on Page 6. Be careful to observe polarity.

Verify that both doors are closed & apply power to the controller.

### Step 7. UR2-4 Controller Startup and Operation Verification.

Verify the polarity of the Door Monitoring Inputs by observing the Status Lights located on the lower right of the UR2-4 controller.

Status Lights A1 & B1 will be OFF if Dip Switch 2-5 = OFF, or will be ON if Dip Switch 2-5 = ON.

Test the standard operation of the interlock by opening either door. The other door will lock until the opened door returns to its normal state (closed).

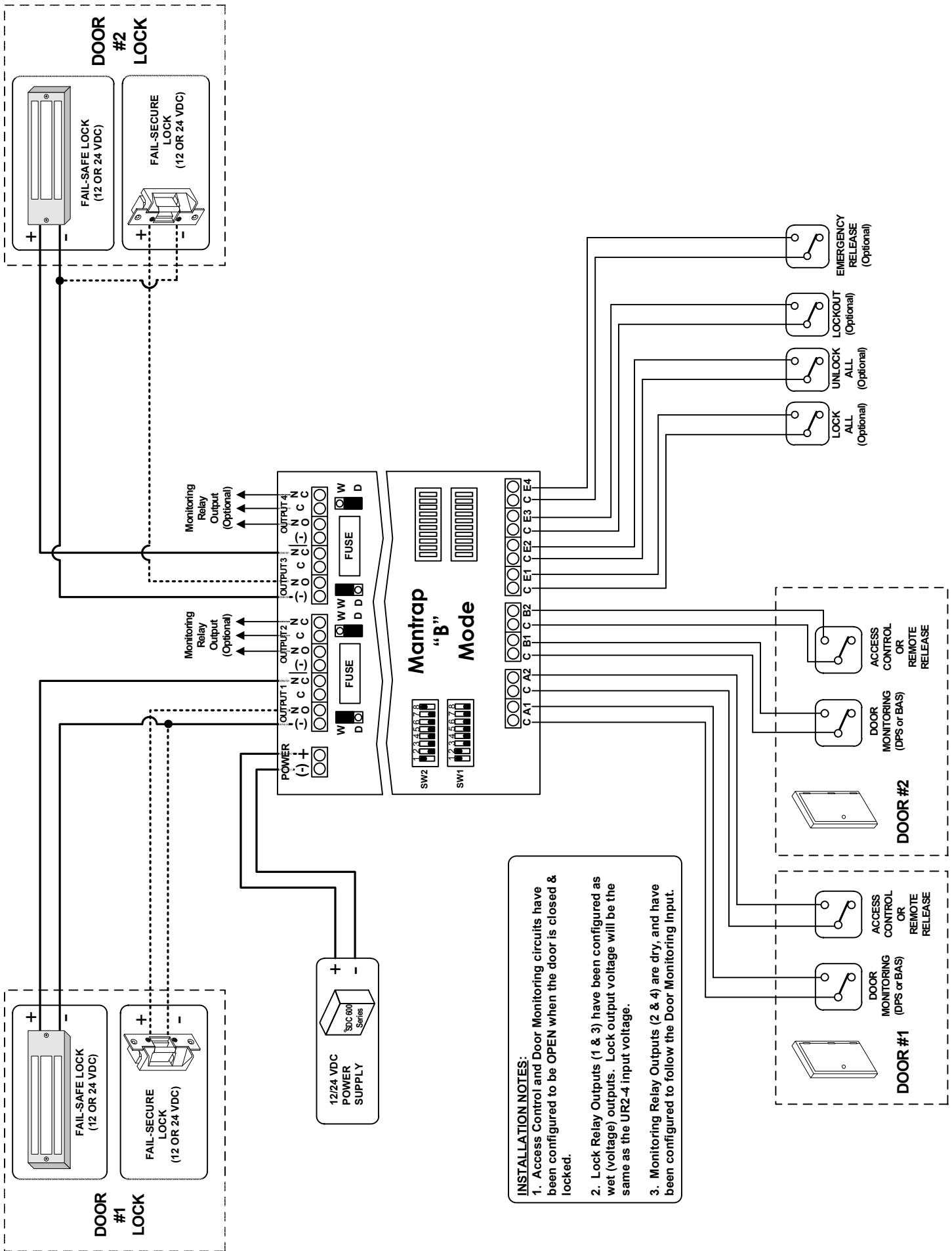

**INSTALLATION NOTES:**

1. Access Control and Door Monitoring circuits have been configured to be OPEN when the door is closed & locked.
2. Lock Relay Outputs (1 & 3) have been configured as wet (voltage) outputs. Lock output voltage will be the same as the UR2-4 input voltage.
3. Monitoring Relay Outputs (2 & 4) are dry, and have been configured to follow the Door Monitoring Input.

## VI. 2-Door Mantrap “B” Setup

Follow the installation steps below before applying power to the UR2-4. Refer to the **MANTRAP “B” MODE** wiring diagram on **Page 8**.

**NOTE:** It is assumed that the UR2-4 and locking hardware share the same power supply.

### Mantrap “B” Standard Operation:

Both doors are normally closed and locked. Each door may be individually unlocked using the Access Control System or a remote release. Unlocking either door causes the other door to be incapable of being unlocked until the unlocked door returns to its normal state.

The door unlock time will be determined by the Access Control System and by Dip Switches 2-1 through 2-4 (See Step 1).

### Step 1 – Set Dip Switches

The dip switch settings below are an example of a typical Mantrap B setup as shown on Page 8. Adjust the dip switch settings as needed.

SW1-1 = ON	Normally Locks Door #1. This switch <u>must</u> be set ON for Mantrap “B” Mode
SW1-2 = ON	Normally Locks Door #2. This switch <u>must</u> be set ON for Mantrap “B” Mode
SW1-3 = OFF	
SW1-4 = OFF	
SW1-5 = OFF	
SW1-6 = OFF	
SW1-7 = OFF	
SW1-8 = OFF	This switch <u>must</u> be set OFF for Mantrap “B” Mode
SW2-1 = ON	SW2-1 through 2-4 set the unlock time of the Lock Relay. <b>NOTE</b> : This is in addition to your Access Control System unlock time.
SW2-2 = OFF	SW2-1 ON = 5 sec., OFF = 0 sec.;
	SW2-2 ON = 10 sec., OFF = 0 sec.;
SW2-3 = OFF	SW2-3 ON = 20 sec., OFF = 0 sec.;
	SW2-4 ON = 30 sec., OFF = 0 sec.;
SW2-4 = OFF	Switch times are additive. {All OFF = 1 sec.; All ON = 65 sec.}
SW2-5 = OFF	Sets the polarity of the Door Monitoring Inputs when the door is in the CLOSED and/or LOCKED position. {OFF = N/O; ON = N/C}
SW2-6 = OFF	Sets the polarity of Access Control Inputs when the switch is in a normal (resting) state. {OFF = N/O; ON = N/C}
SW2-7 = OFF	Sets the operation of all the Monitoring Relay Outputs. {OFF = Relay will follow the Door Monitoring Input; ON = Relay will follow the Lock Output Relay}
SW2-8 = ON	Switches the UR board between Interlock Mode or Control Mode. This switch <u>must</u> be set ON.

### Step 2 – Configure the Relay Outputs to be Wet (Voltage) or Dry.

Use the red WET/DRY Selection Jumpers to configure each output. Refer to Page 2 of this instruction for selection procedure.

On the typical Mantrap B wiring diagram, the Lock Relays (Outputs 1 & 3) are configured to be wet outputs.

The Monitoring Relays (Outputs 2 & 4) are dry.

**NOTE:** It is recommended that any unused relays be configured as dry outputs.

### Step 3. Terminate the Lock Power Wiring

Follow the typical Mantrap B wiring diagram for fail-safe or fail-secure locks. Be careful to observe lock voltage polarity.

**NOTE:** All low voltage wiring shall be 18-gauge minimum. The minimum lock power wire gauge shall be determined by the SDC wire gauge chart. Signal wire shall be 22-gauge minimum.

### Step 4. Terminate the Access Control and Door Monitoring Inputs

Connect the Door Monitoring Switches to input terminals A1 & B1. This is a required connection.

Connect Access Control or remote releases to input terminals A2 & B2. This is a required connection.

Door Monitoring and Access Control inputs should be dry, Normally Open or Normally Closed switches, depending on the configuration of Dip Switches 2-5 and 2-6, respectively.

**NOTE:** Dip Switch 2-5 configures the normal state of the Door Monitoring input when the door is in a CLOSED and/or LOCKED position.

### Step 5. Terminate Optional Inputs and Outputs

**Auxiliary Inputs** – These inputs must be wired to dry, Normally Open switches. The input will only be active when closed (shorted). Refer to Page 2 for input descriptions.

**Monitoring Relay Outputs** – Each door station provides a non-fused, SPDT monitoring relay. This output may be used to signal a Security Panel or to activate a Remote Annunciator. The relay is configurable as a Wet or Dry output (Step 2). The relay activation will follow the Lock Relay or follow the Door Monitoring Input, depending on the configuration of Dip Switch 2-7 (Step 1).

### Step 6. Connect a 12 or 24VDC Power Source to the UR2-4 Controller.

Before applying power, verify that all the connections are securely terminated by gently pulling on each wire.

Terminate the voltage wiring to the Controller Power Input. Be careful to observe polarity.

Verify that both doors are closed & apply power to the controller.

### Step 7. UR2-4 Controller Startup and Operation Verification.

Verify the polarity of the Access Control & Door Monitoring Inputs by observing the Status Lights located on the lower right of the UR2-4 controller.

Status Lights A1 & B1 will be OFF if Dip Switch 2-5 = OFF, or will be ON if Dip Switch 2-5 = ON.

Status Lights A2 & B2 will be OFF if Dip Switch 2-6 = OFF, or will be ON if Dip Switch 2-6 = ON.

Test the standard operation of the mantrap by unlocking a door using the Access Control System or remote release. The other door will be incapable of being unlocked until the unlocked door returns to its normal state (closed & locked).

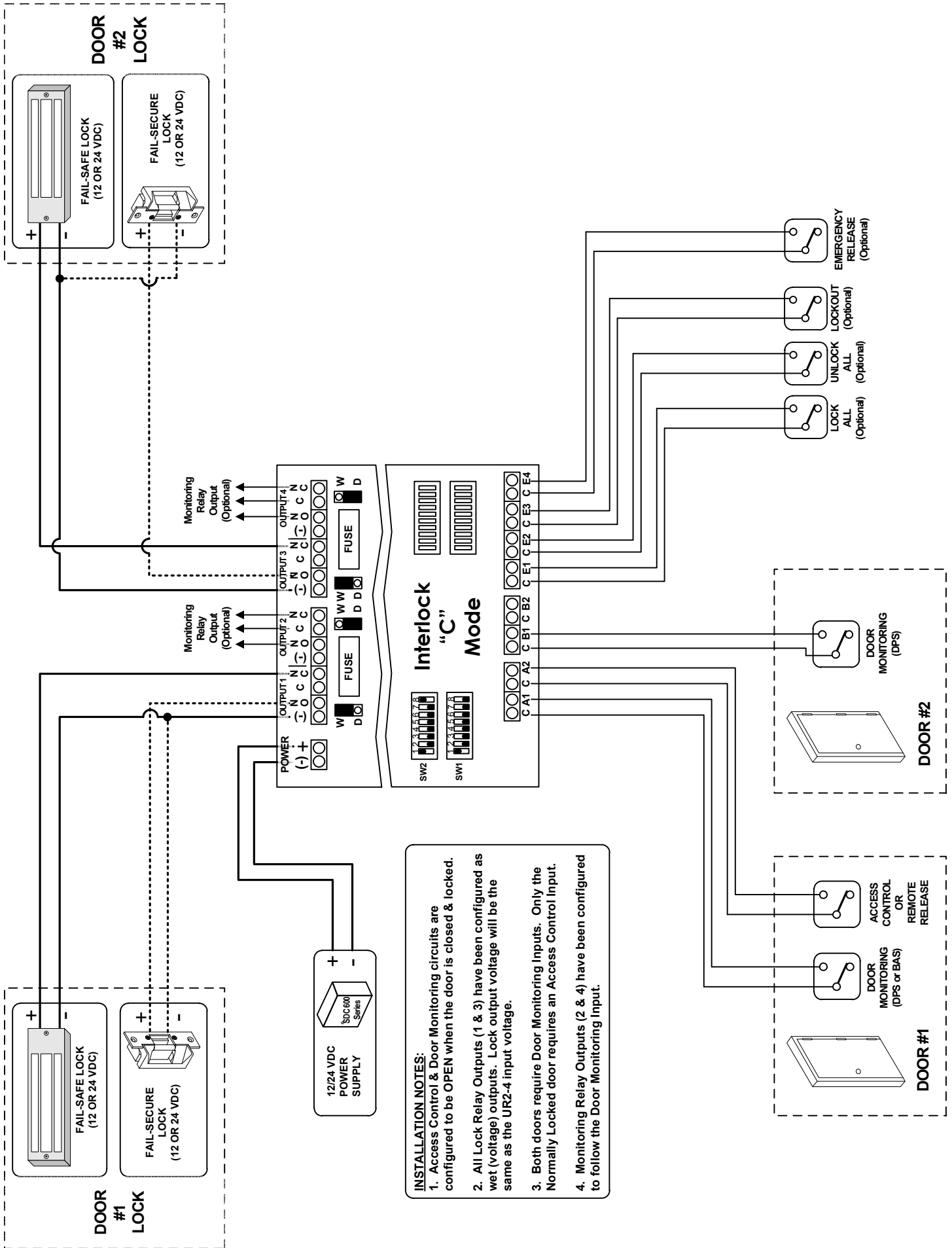

**INSTALLATION NOTES:**

1. Access Control & Door Monitoring circuits are configured to be OPEN when the door is closed & locked.
2. All Lock Relay Outputs (1 & 3) have been configured as wet (voltage) outputs. Lock output voltage will be the same as the UR2-4 input voltage.
3. Both doors require Door Monitoring Inputs. Only the Normally Locked door requires an Access Control Input.
4. Monitoring Relay Outputs (2 & 4) have been configured to follow the Door Monitoring Input.

## VII. 2-Door Interlock “C” Setup

Follow the installation steps below before applying power to the UR2-4. Refer to the **INTERLOCK “C” MODE** wiring diagram on **Page 10**.

NOTE: It is assumed that the UR2-4 and locking hardware share the same power supply.

### Interlock “C” Standard Operation:

Both doors are normally closed. One door will be normally locked, and the other door will be normally unlocked.

Unlocking/opening the locked door will lock the unlocked door, until the unsecured door returns to its normal state. Opening the unlocked door will make the locked door incapable of being unlocked, until the opened door returns to its normal state.

The locked door may be accessed by activating the Access Control System or a remote release. The door unlock time will be determined by the Access Control System and by Dip Switches 2-1 through 2-4 (See Step 1).

### Step 1 – Set Dip Switches

The dip switch settings below are an example of a typical Interlock “C” setup as shown on Page 10. Adjust the dip switch settings as needed.

SW1-1 = ON	{ON = Door 1 - Locked}
SW1-2 = OFF	{OFF = Door 2 - Unlocked}
SW1-3 = OFF	
SW1-4 = OFF	
SW1-5 = OFF	
SW1-6 = OFF	
SW1-7 = OFF	
SW1-8 = OFF	This switch must be set OFF for Interlock “C” Mode
SW2-1 = ON	SW2-1 through 2-4 set the unlock time of the Lock Relay for the Door 1.
SW2-2 = OFF	<b>NOTE</b> : This is in addition to your Access Control System unlock time.
SW2-3 = OFF	SW2-1 ON = 5 sec., OFF = 0 sec.;
	SW2-2 ON = 10 sec., OFF = 0 sec.;
	SW2-3 ON = 20 sec., OFF = 0 sec.;
SW2-4 = OFF	SW2-4 ON = 30 sec., OFF = 0 sec.;
	Switch times are additive. {All OFF = 1 sec.; All ON = 65 sec.}
SW2-5 = OFF	Sets the polarity of the Door Monitoring Inputs when the door is in the CLOSED position. {OFF = N/O; ON = N/C}
SW2-6 = OFF	Sets the polarity of Access Control Inputs when the switch is in a normal (resting) state. {OFF = N/O; ON = N/C}
SW2-7 = OFF	Sets the operation of all the Monitoring Relay Outputs. {OFF = Relay will follow the Door Monitoring Input; ON = Relay will follow the Lock Output Relay}
SW2-8 = ON	Switches the UR board between Interlock Mode or Control Mode. This switch must be set ON.

### Step 2 – Configure the Relay Outputs to be Wet (Voltage) or Dry.

Use the red WET/DRY Selection Jumpers to configure each output. Refer to Page 2 of this instruction for selection procedure.

On the typical Interlock C wiring diagram, the Lock Relays (Outputs 1 & 3) are configured to be wet outputs. The Monitoring Relays (Outputs 2 & 4) are dry.

**NOTE:** It is recommended that any unused relays be configured as dry outputs.

### Step 3. Terminate the Lock Power Wiring

Follow the typical Interlock “C” wiring diagram for fail-safe or fail-secure locks. Be careful to observe lock voltage polarity.

**NOTE:** All low voltage wiring shall be 18-gauge minimum. The minimum lock power wire gauge shall be determined by the SDC wire gauge chart. Signal wire shall be 22-gauge minimum.

### Step 4. Terminate the Access Control and Door Monitoring Inputs

Connect the Door Monitoring Switches to input terminals A1 & B1. This is a required connection.

Connect Access Control or remote release to input terminals A2. This connection is ONLY required for the normally locked door.

Door Monitoring and Access Control inputs should be dry, Normally Open or Normally Closed switches, depending on the configuration of Dip Switches 2-5 and 2-6, respectively.

**NOTE:** Dip Switch 2-5 configures the normal state of the Door Monitoring input when the door is in a CLOSED and/or LOCKED position.

### Step 5. Terminate Optional Inputs and Outputs

**Auxiliary Inputs** – These inputs must be wired to dry, Normally Open switches. The input will only be active when closed (shorted). Refer to Page 2 for input descriptions.

**Monitoring Relay Outputs** – Each door station provides a non-fused, SPDT monitoring relay. This output may be used to signal a Security Panel or to activate a Remote Annunciator. The relay is configurable as a Wet or Dry output (Step 2). The relay activation will follow the Lock Relay or follow the Door Monitoring Input, depending on the configuration of Dip Switch 2-7 (Step 1).

### Step 6. Connect a 12 or 24VDC Power Source to the UR2-4 Controller.

Before applying power, verify that all the connections are securely terminated by gently pulling on each wire.

Terminate the voltage wiring to the Controller Power Input. Be careful to observe polarity.

Verify that both doors are closed & apply power to the controller.

### Step 7. UR2-4 Controller Startup and Operation Verification.

Verify the polarity of the Access Control & Door Monitoring Inputs by observing the Status Lights located on the lower right of the UR2-4 controller.

Status Lights A1 & B1 will be OFF if Dip Switch 2-5 = OFF, or will be ON if Dip Switch 2-5 = ON.

Status Light A2 will be OFF if Dip Switch 2-6 = OFF, or will be ON if Dip Switch 2-6 = ON.

Test the standard operation of the interlock by accessing the locked door or by opening the unlocked door(s). The other door will be incapable of being opened/unlocked until the accessed door returns to its normal state.

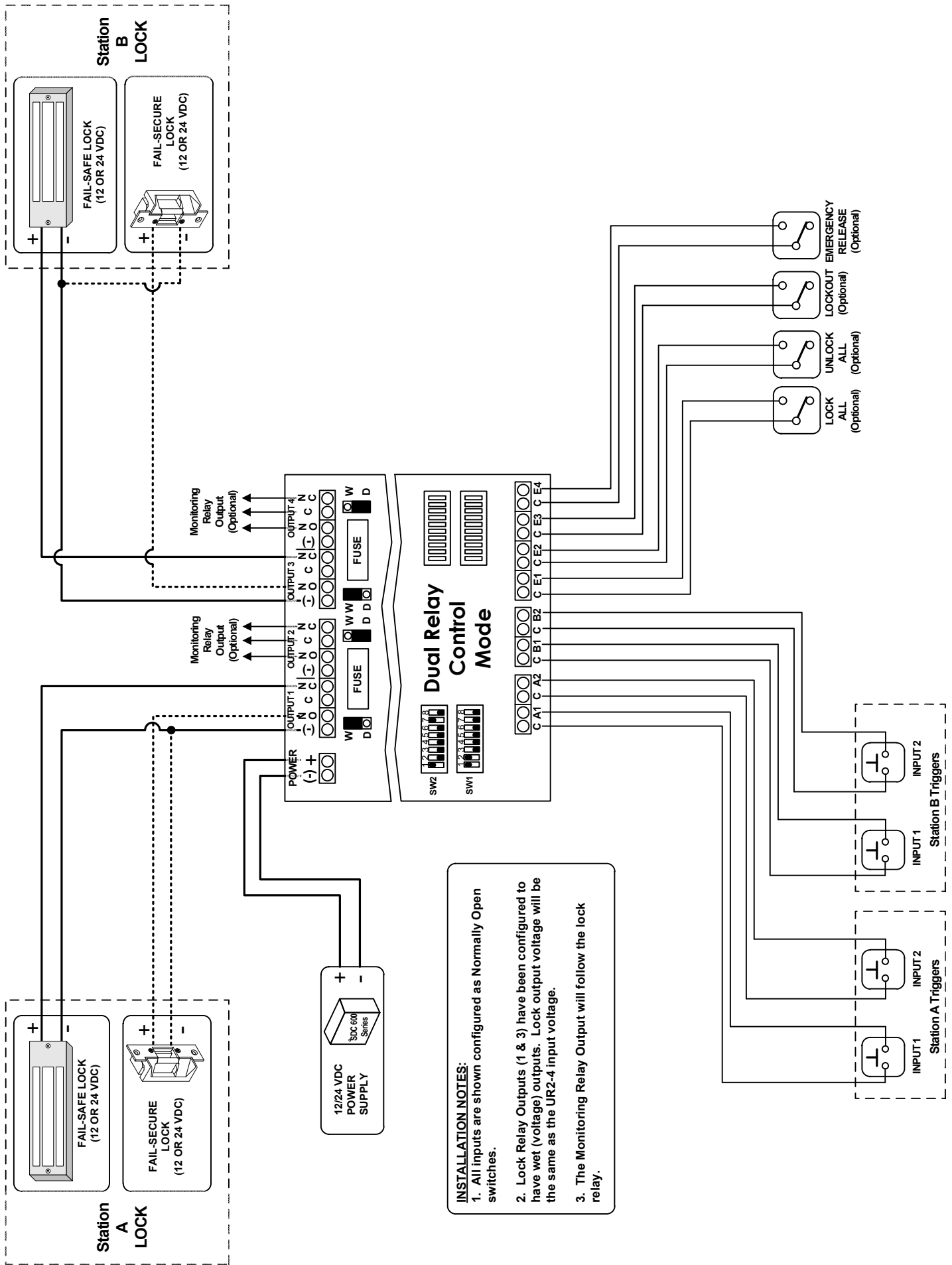

**INSTALLATION NOTES:**

1. All inputs are shown configured as Normally Open switches.
2. Lock Relay Outputs (1 & 3) have been configured to have wet (voltage) outputs. Lock output voltage will be the same as the UR2-4 input voltage.
3. The Monitoring Relay Output will follow the lock relay.

## VIII. Dual Relay Control Mode Setup

Follow the installation steps below before applying power to the UR2-4. Refer to the **DUAL RELAY CONTROL MODE** wiring diagram on Page 12.

NOTE: It is assumed that the UR2-4 and locks will share the same power supply.

### Standard Operation:

In Dual Relay Control Mode, the UR2-4 operates as two (2) individually controlled relay stations.

Activating each station's Input 1 OR Input 2 will trigger the corresponding lock output AND the auxiliary output simultaneously.

Inputs A1 & B1 may each be configured to operate as a conventional relay (CR) or a time delayed relay (TD).

Inputs A2 & B2 may each be configured to operate as a conventional relay or a latching relay (LR).

Refer to Page 3 of this instruction for relay operation descriptions.

### Step 1 – Set Dip Switches

The dip switch settings below are an example of a typical Dual Relay Control Mode Setup as shown on Page 12. Adjust the dip switch settings as required.

Use dip switches SW1-1 through SW1-4 to select the operation of each trigger input: CR, TD, or LR.

SW1-1 = ON	Station A, Input 1 Mode Selection {OFF = CR; ON = TD}
SW1-2 = ON	Station A, Input 2 Mode Selection {OFF = CR; ON = LR}
SW1-3 = OFF	Station B, Input 1 Mode Selection {OFF = CR; ON = TD}
SW1-4 = OFF	Station B, Input 2 Mode Selection {OFF = CR; ON = LR}
SW1-5 = OFF	
SW1-6 = OFF	
SW1-7 = OFF	
SW1-8 = OFF	
SW2-1 = ON	When using TD mode, SW2-1 through 2-4 sets the unlock delay time of the relays.
SW2-2 = OFF	SW2-1 ON = 5 sec., OFF = 0 sec.;
	SW2-2 ON = 10 sec., OFF = 0 sec.;
SW2-3 = OFF	SW2-3 ON = 20 sec., OFF = 0 sec.;
	SW2-4 ON = 30 sec., OFF = 0 sec.;
SW2-4 = OFF	Switch times are additive. {All OFF = 1 sec.; All ON = 65 sec.}
SW2-5 = OFF	Sets the polarity of ALL the trigger inputs when the trigger is in a non-activated state. {OFF = N/O; ON = N/C}
SW2-6 = OFF	This switch <u>must</u> be set OFF for Dual Relay Mode.
SW2-7 = ON	This switch <u>must</u> be set ON for Dual Relay Mode.
SW2-8 = OFF	This switch <u>must</u> be set OFF for Dual Relay Mode.

### Step 2 – Configure the Relay Outputs to be Wet (Voltage) or Dry.

Use the red WET/DRY Selection Jumpers to configure each output. Refer to Page 2 of this instruction for selection procedure.

On the typical Dual Relay Control Mode wiring diagram, the Lock Relays (Outputs 1 & 3) are configured to be wet outputs. The Monitoring Relays (Outputs 2 & 4) are dry. The relay output voltage will be the same as the UR2-4 input voltage (12 or 24 VDC).

NOTE: It is recommended that any unused relays be configured as dry outputs.

### Step 3. Terminate the Lock Power Wiring

Follow the typical Dual Relay Control Mode wiring diagram for fail-safe or fail-secure locks. Be careful to observe lock voltage polarity.

NOTE: All low voltage wiring shall be 18-gauge minimum. The minimum lock power wire gauge shall be determined by the SDC wire gauge chart. Signal wire shall be 22-gauge minimum.

### Step 4. Terminate the Station Trigger Inputs

Connect each station's trigger input 1 and input 2, as required.

All the trigger inputs should be dry, momentary, Normally Open or Normally Closed switches, depending on the configuration of Dip Switch 2-5 (Step 1).

NOTE: If Normally Closed inputs are used, all unused trigger inputs will need to be shorted.

### Step 5. Terminate Optional Inputs and Outputs

Auxiliary Inputs – These inputs must be wired to dry, Normally Open switches. The input will only be active when closed (shorted). Refer to Page 2 for input descriptions.

Monitoring Relay Outputs – Each door station provides a non-fused, SPDT monitoring relay. This output may be used to signal a Security Panel or to activate a Remote Annunciator. The relay is configurable as a Wet or Dry output (Step 2). The relay activation will follow the Lock Relay.

### Step 6. Connect a 12 or 24VDC Power Source to the UR2-4 Controller.

Before applying power, verify that all the connections are securely terminated by gently pulling on each wire.

Terminate the voltage wiring to the Controller Power Input. Be careful to observe polarity.

Verify that all the trigger inputs are in their normal (resting) state & apply power to the controller.

### Step 7. UR2-4 Controller Startup and Operation Verification.

Verify the polarity of each Station trigger input by observing the Status Lights located on the lower right of the controller.

Status Lights A1, A2, B1, & B2 will be OFF if Dip Switch 2-5 = OFF, or will be ON if Dip Switch 2-5 = ON.

Test the standard operation of each station control relay by momentarily pressing the trigger input.

In CR mode, the respective door will unlock while the trigger input is activated, and relock when the trigger is released.

In TD mode, the respective door will unlock when the trigger input is activated. Releasing the trigger input will start the unlock timer and the door will remain unlocked. The door will relock after the set unlock time has expired.

In LR mode, the respective door will unlock when the trigger input is momentarily activated and released. The door will remain unlocked indefinitely until the trigger input is reactivated.

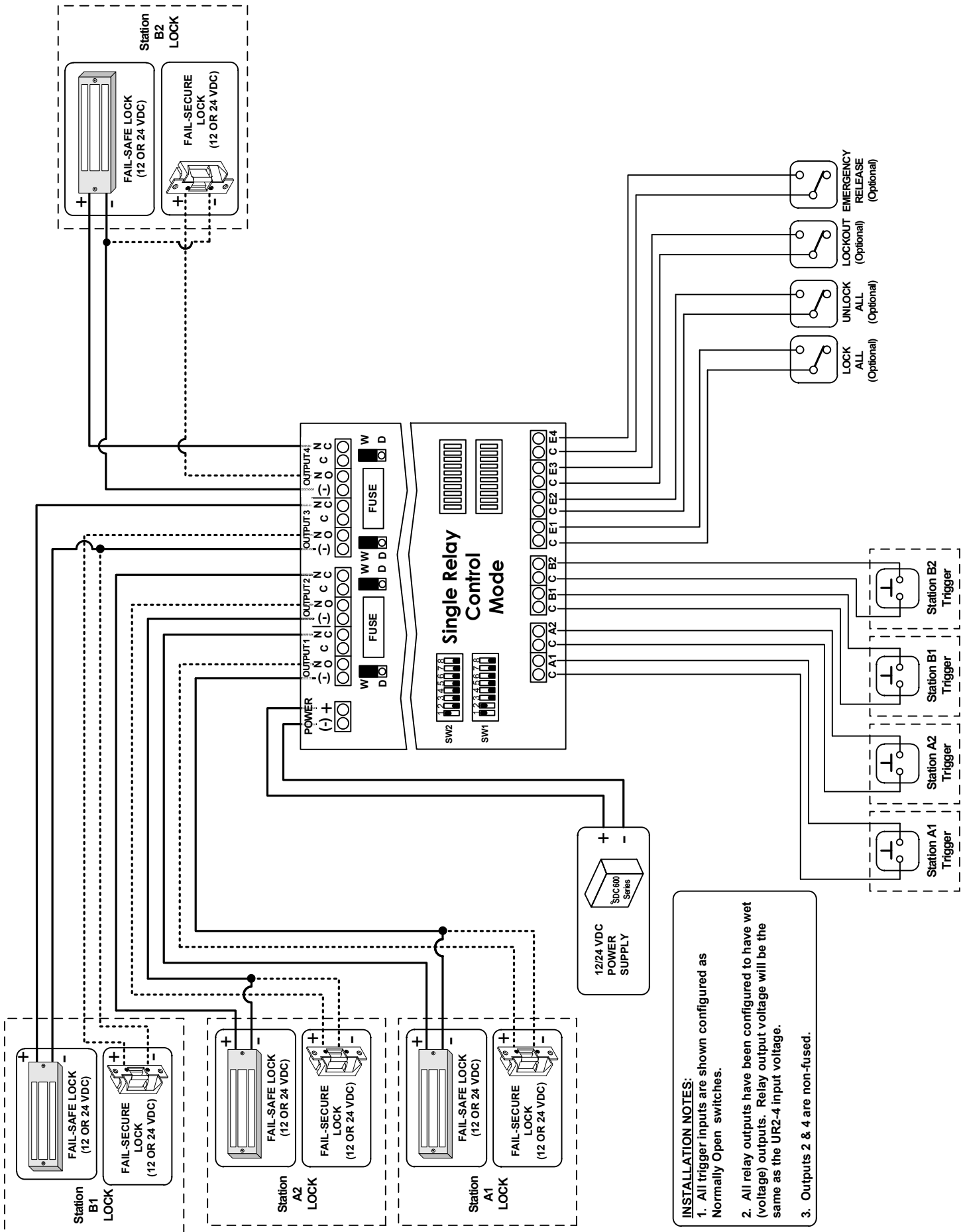

**INSTALLATION NOTES:**

1. All trigger inputs are shown configured as Normally Open switches.
2. All relay outputs have been configured to have wet (voltage) outputs. Relay output voltage will be the same as the UR2-4 input voltage.
3. Outputs 2 & 4 are non-fused.

## IX. Single Relay Control Mode Setup

Follow the installation steps below before applying power to the UR2-4. Refer to the **SINGLE RELAY CONTROL MODE** wiring diagram on Page 14.

NOTE: It is assumed that the UR2-4 and locks will share the same power supply.

### Standard Operation:

In Single Relay Control Mode, the UR2-4 operates as four (4) individually controlled relay stations. Each trigger input controls a single output.

Each input may be individually configured to operate as a conventional relay (CR) or a time delayed relay (TD).

Alternatively, each input may be individually configured to operate as a latching relay (LR) or a time delayed relay.

Refer to Page 4 of this instruction for relay operation descriptions.

### Step 1 – Set Dip Switches

The dip switch settings below are an example of a typical Single Relay Control Mode Setup as shown on Page 14. Adjust the dip switch settings as required.

Use dip switches SW1-1 through SW1-4 to select the operation of each trigger input: CR, TD, or LR.  
If dip switch SW2-6 = OFF, each input is selectable as a CR or TD only.  
If dip switch SW2-6 = ON, each input is selectable as a LR or TD only.

SW1-1 = ON	Station A1 Mode Selection {OFF = CR or LR; ON = TD}
SW1-2 = ON	Station A2 Mode Selection {OFF = CR or LR; ON = TD}
SW1-3 = OFF	Station B1 Mode Selection {OFF = CR or LR; ON = TD}
SW1-4 = OFF	Station B2 Mode Selection {OFF = CR or LR; ON = TD}
SW1-5 = OFF	
SW1-6 = OFF	
SW1-7 = OFF	
SW1-8 = OFF	
SW2-1 = ON	When using TD mode, SW 2-1 through 2-4 set the unlock delay time of the Lock Relay.
SW2-2 = OFF	SW2-1 ON = 5 sec., OFF = 0 sec.;
SW2-3 = OFF	SW2-2 ON = 10 sec., OFF = 0 sec.;
SW2-4 = OFF	SW2-3 ON = 20 sec., OFF = 0 sec.;
	SW2-4 ON = 30 sec., OFF = 0 sec.;
	Switch times are additive. {All OFF = 1 sec.; All ON = 65 sec.}
SW2-5 = OFF	Sets the polarity of ALL the trigger inputs when the trigger is in a non-activated state. {OFF = N/O; ON = N/C}
SW2-6 = OFF	{OFF = Each trigger input is selectable as CR or TD only; ON = Each trigger input is selectable as LR or TD only}
SW2-7 = OFF	This switch <u>must</u> be set OFF for Single Relay Mode.
SW2-8 = OFF	This switch <u>must</u> be set OFF for Single Relay Mode.

### Step 2 – Configure the Relay Outputs to be Wet (Voltage) or Dry.

Use the red WET/DRY Selection Jumpers to configure each output. Refer to Page 2 of this instruction for selection procedure.

On the typical Single Relay Control Mode wiring diagram, all relay outputs are configured as wet outputs.

The relay output voltage will be the same as the UR2-4 input voltage (12 or 24 VDC).

NOTE: It is recommended that any unused relays be configured as dry outputs.

### Step 3. Terminate the Lock Power Wiring

Follow the Single Relay Control Mode wiring diagram for fail-safe or fail-secure locks. Be careful to observe lock voltage polarity.

NOTE: All low voltage wiring shall be 18-gauge minimum. The minimum lock power wire gauge shall be determined by the SDC wire gauge chart. Signal wire shall be 22-gauge minimum.

### Step 4. Terminate the Station Trigger Inputs

Connect each station's trigger input as required.

All the trigger inputs should be dry, momentary, Normally Open or Normally Closed switches, depending on the configuration of Dip Switch 2-5 (Step 1).

NOTE: If Normally Closed inputs are used, all unused trigger inputs will need to be shorted.

### Step 5. Terminate Optional Inputs and Outputs

Auxiliary Inputs – These inputs must be wired to dry, Normally Open switches. The input will only be active when closed (shorted). Refer to Page 2 for input descriptions.

### Step 6. Connect a 12 or 24VDC Power Source to the UR2-4 Controller.

Before applying power, verify that all the connections are securely terminated by gently pulling on each wire.

Terminate the voltage wiring to the Controller Power Input. Be careful to observe polarity.

Verify that all the trigger inputs are in their normal (resting) state & apply power to the controller.

### Step 7. UR2-4 Controller Startup and Operation Verification.

Verify the polarity of each Station trigger input by observing the Status Lights located on the lower right of the controller.

Status Lights A1, A2, B1, & B2 will be OFF if Dip Switch 2-5 = OFF, or will be ON if Dip Switch 2-5 = ON.

Test the standard operation of each station control relay by momentarily pressing the trigger input.

In CR mode, the respective door will unlock while the trigger input is activated, and relock when the trigger is released.

In TD mode, the respective door will unlock when the trigger input is activated. Releasing the trigger input will start the unlock timer and the door will remain unlocked. The door will relock after the set unlock time has expired.

In LR mode, the respective door will unlock when the trigger input is momentarily activated and released. The door will remain unlocked indefinitely until the trigger input is reactivated.

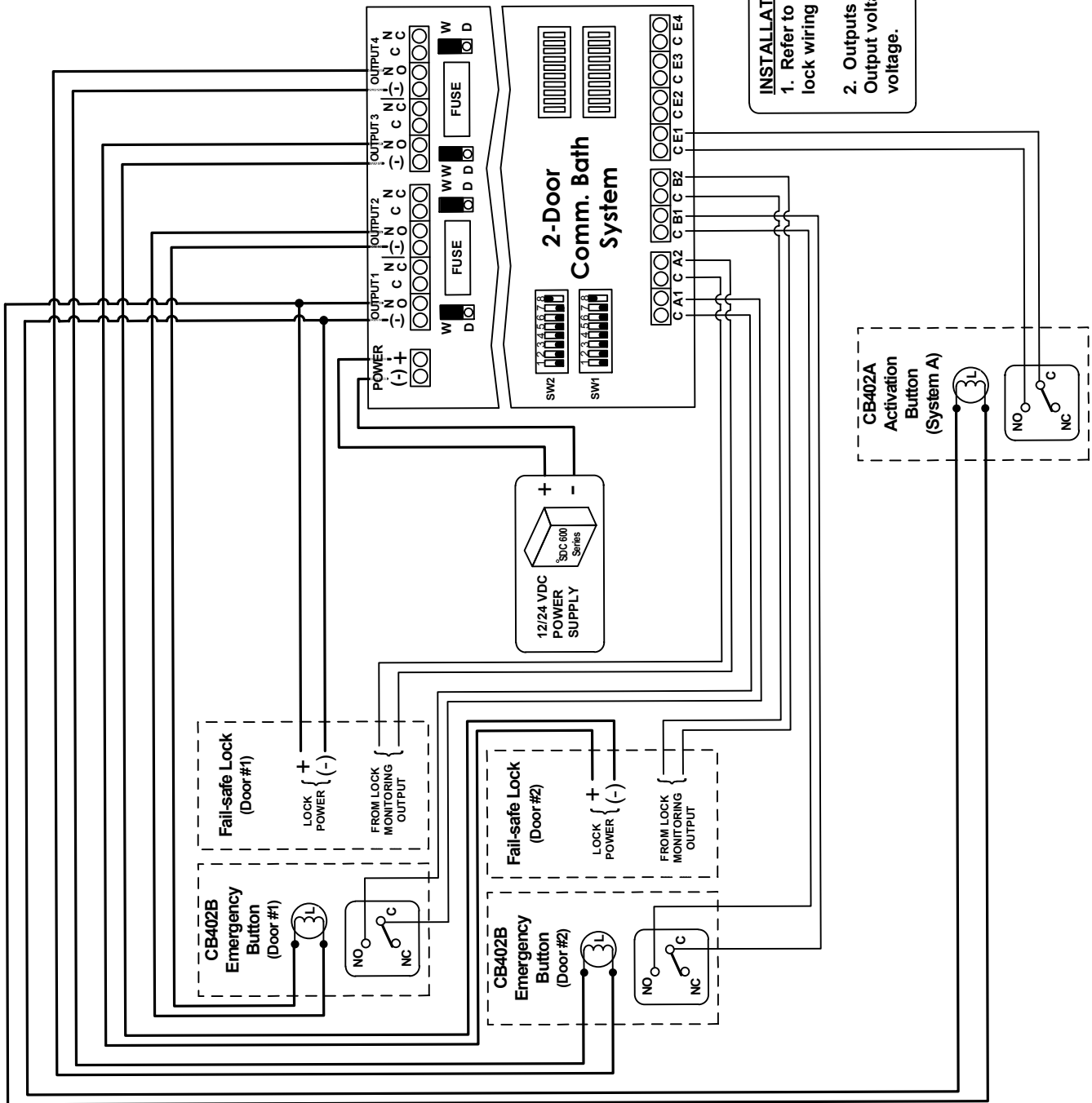

**INSTALLATION NOTES:**

1. Refer to the lock's installation instructions for the lock wiring details.
2. Outputs 1- 4 are configured as wet (voltage) outputs. Output voltage will be the same as the UR2-4 input voltage.

## X. 2-Door Communicating Bath System

### Setup

Follow the installation steps below before applying power to the UR2-4.

Refer to the **2-Door Communicating Bath System** wiring diagram on **Page 16**.

It is assumed that the UR2-4 and locks will share the same power supply.

### Step 1 – Set Dip Switches

The dip switch settings for a 2-Door Communicating Bath System must be set as shown below.

SW1-1 = OFF	
SW1-2 = OFF	
SW1-3 = OFF	
SW1-4 = OFF	
SW1-5 = OFF	
SW1-6 = OFF	
SW1-7 = OFF	
SW1-8 = ON	This switch <u>must</u> be set ON for Comm. Bath Mode
<hr/>	
SW2-1 = OFF	
SW2-2 = OFF	
SW2-3 = OFF	
SW2-4 = OFF	
SW2-5 = OFF	
SW2-6 = OFF	
SW2-7 = OFF	
<hr/>	
SW2-8 = ON	Switches the UR board between Interlock Mode or Control Mode. This switch <u>must</u> be set ON for Comm. Bath Mode

### Step 2 – Configure the Relay Outputs to be Wet (Voltage) or Dry.

Use the red WET/DRY Selection Jumpers to configure each output. Refer to Page 2 of this instruction for selection procedure.

For a 2-Door Communicating Bath System, all outputs (1 through 4) are configured as wet outputs.

The relay output voltage will be the same as the UR2-4 input voltage (12 or 24VDC).

### Step 3. Terminate the Activation and Emergency Unlock Buttons

Connect the (2) Emergency Unlock buttons and (1) Activation button as shown on the Communicating Bath system wiring diagram.

**NOTE:** Each Emergency Unlock button will only unlock its corresponding door.

All button switches are wired Normally Open.

Lamp voltage is not polarity sensitive.

**NOTE:** All low voltage wiring shall be 18-gauge minimum. The minimum lock power wire gauge shall be determined by the SDC wire gauge chart. Signal wire shall be 22-gauge minimum.

### Step 4. Terminate the Lock Power and Lock Monitoring Options

Select your specific lock type below. Follow the typical Communicating Bath system wiring diagram. Be careful to observe lock voltage polarity.

**NOTE:** All lock monitoring options below (LBM, DPS, and/or REX) are to be wired OPEN when the doors are CLOSED and LATCHED.

*Using EMLocks®:*

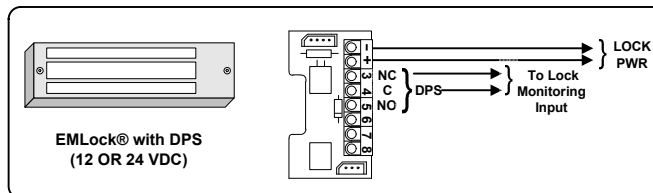

*Using Fail-safe Uni-FLEX™ Electric Strikes:*

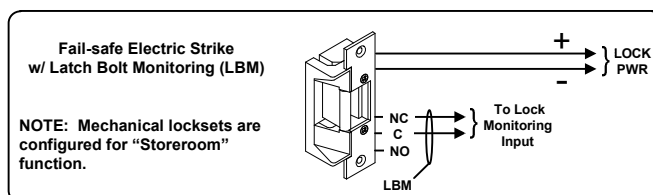

*Using Fail-safe Selectric® Pro Locks:*

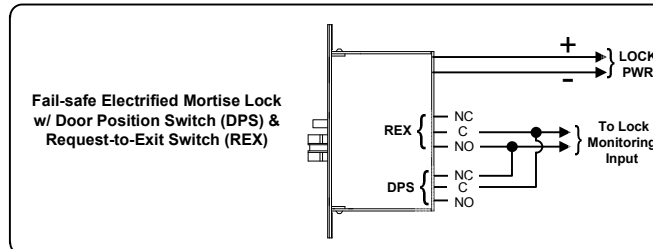

### Step 6. Connect a 12 or 24VDC Power Source to the UR2-4 Controller.

Before applying power, verify that all the connections are securely terminated by gently pulling on each wire.

Terminate the voltage wiring to the Controller Power Input. Be careful to observe polarity.

Verify that both doors are closed & apply power to the controller.

### Step 7. UR2-4 Controller Startup and Operation Verification.

Verify the polarity of the inputs by observing the Status Lights located on the lower right of the controller.

With the system at rest, Status Lights A1, A2, B1, B2, & E1 should all be turned off.

Test the standard operation of the Communicating Bath System as described on Page 4.