

SDC SECURITY DOOR CONTROLS

801 Avenida Acaso, Camarillo, Ca. 93012 • (805) 494-0622 • Fax: (805) 494-8861
www.sdcsecurity.com • E-mail: service@sdsecurity.com

INSTALLATION INSTRUCTIONS MICRO SHEAR EMLOCKS 1561 & 1562 MAX. HOLDING FORCE 2000 LBS.

REFER TO THE PROPER TEMPLATE ACCORDING TO THE TYPE OF DOOR AND FRAME APPLICATION.

READ THESE INSTRUCTIONS AND STUDY THE TEMPLATE THOROUGHLY BEFORE BEGINNING THE INSTALLATION.

IMPORTANT NOTES:

Although electromagnetic shear locks provide the utmost in aesthetics for fail-safe applications, they are less forgiving than electric bolt locks and direct pull magnetic locks where alignment problems exist. Therefore, great care must be taken during preparation and installation of the frame, door hardware and the shear Emlock to attain proper alignment and ensure positive lock operation.

Unbalanced air conditioning (stack pressure) can hinder door alignment and must be corrected to help ensure positive locking.

Use only the highest quality door closer.

POSITIVE CENTERING DOOR CLOSERS ONLY should be used on double acting doors to help attain consistent dead center alignment.

Door latching problems must be corrected prior to installation.

The maximum locking strength of the 1561/1562 Hi/Shear Emlock is 2000 lbs.

INSTALLATION:

1. Make sure the clearance between the door top rail and frame header is 1/8". Make adjustments to the door as required.
2. Adjust single acting door and door closer to ensure the door settles immediately and is fully closed and at rest against the stop allowing for mutes, smoke seals or weather stripping where applicable.

Adjust double acting door and POSITIVE CENTERING DOOR CLOSER to ensure the door settles immediately and is fully closed and at rest in the dead center of the frame.

3. Locate the vertical centerline of the Emlock and armature as close as possible to the leading door edge.
CAUTION: Wood door applications require the armature back box to be located and ample distance from the door edge vertical grains, to avoid splitting from wood screws.

4. Determine the horizontal centerline of the door top rail thickness. The armature centerline will be the same.

Mark the door per the template.

5. Before determining the frame header centerline, single acting doors must be fully closed and at rest against the stop allowing for mutes, smoke or weather stripping where applicable. Double acting doors must be fully closed and at rest in the dead center of the frame.
6. Mark the frame header per the template.
7. Prepare the door and frame per the template.
8. An auto relock time delay (built-in with 1561) is recommended for all installations to delay relocking 1 to 6 seconds after initial door closure. This will help ensure the door is fully closed and at rest to obtain optimum alignment before the Emlock is energized. Consult Figure 7A or 7B according to material supplied.

With the power off, make all wire connections to a properly fused power source.

Any suggestions or comments to this instruction or product are welcome. Please contact us through our website or email engineer@sdsecurity.com

9. When installing 1562 model use Figure 7B, make the timer adjustment as required and test the TDA time delay prior to mounting in the frame. The TDA timer is field adjustable for 1 to 6 seconds and is factory set at approximately 3 seconds. turn clockwise to increase and counter clockwise to decrease the delay time.
 10. Install the Emlock and armature with the auto relock switch assembly towards the leading edge of the door.

The 1561 timer adjustment can be made after the Emlock is installed through the small hole in the face of the magnet. Using a small flat blade screwdriver, turn clockwise to increase time, counter clockwise to decrease time.
 11. For proper operation, the armature must be adjusted upward as close as possible and parallel to the Emlock without interfering with opening and closing of the door. Proper operation cannot be expected with more than 1/8" clearance between the armature and the Emlock. If you find the clearance to be more than 1/8", shim the assembly with the shims provided.
 12. With the door closed, turn the lock power on. Check the lateral alignment. The armature shear stops should be centered between each pair of magnet shear stops.
 13. If the clearance between the shear stops is sufficient, open and close the door a few times to ensure the Emlock will lock and unlock positively.
 14. Adjust the auto relock switch magnet to avoid early activation and help ensure positive locking on door closure. Adjust inward to delay Emlock activation. Do not adjust higher than the armature rest position.
 15. If the shear stops are too close or binding, double check the templating and door alignment, and make corrections as required.
 16. If positive locking cannot be attained due to misalignment after the previous adjustments, the armature shear stops can be reversed with the wide clearance shear stops.
- CAUTION: The use of armature offset shear stops may correct misalignment but should not be used when proper door latching is inhibited.**
17. Repeat steps 11 through 15 as necessary following shear stop replacement.
 18. Cycle the door and Emlock several times after the completion of installation.

MODEL #	LOCK DIMENSION			HOLDING FORCE	POWER CONSUPTION		MODEL #	ARMATURE DIMENSION		
	L	W	D		12VDC	24VDC		L	W	D
1561	8"	1-1/2"	1-5/8"	2000	650mA	350mA	ITCM	8-7/16"	1-1/2"	7/8"
1562	8"	1-1/2"	1-1/4"	2000	650mA	350mA	FTCM	8-7/16"	1-1/2"	7/8"
							HTCM	8-7/16"	1-1/2"	7/8"

FIGURE 1

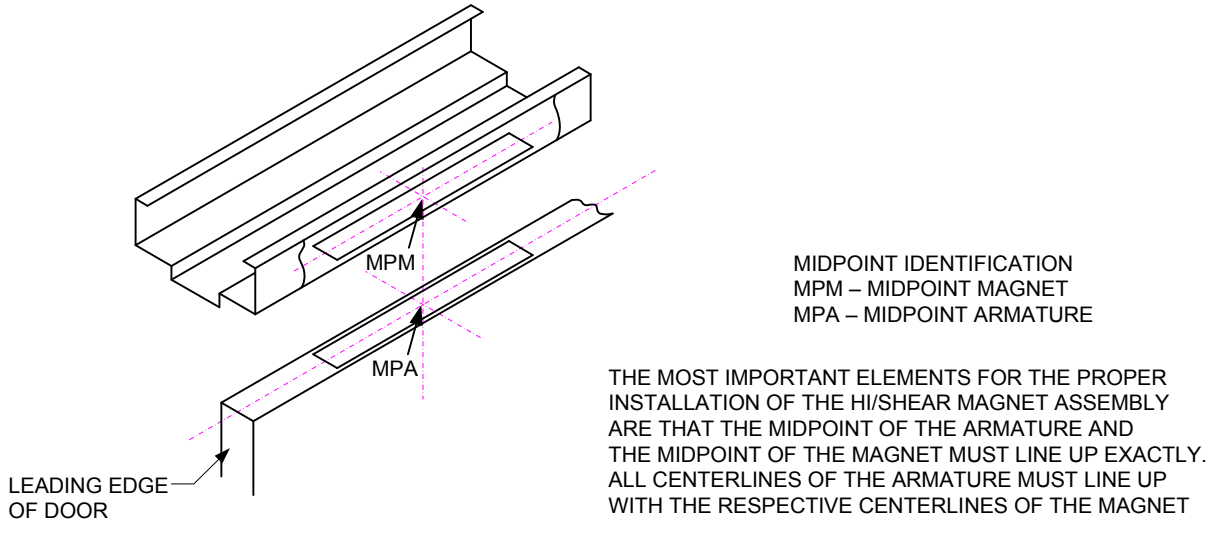

FIGURE 2

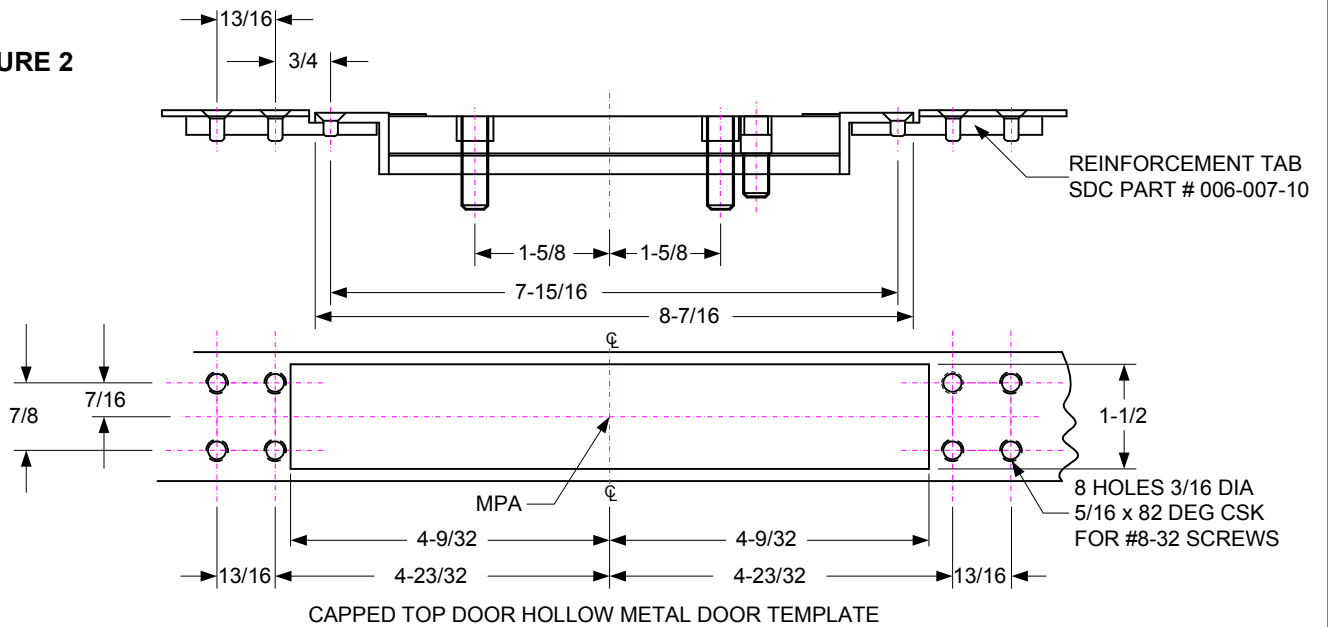

FIGURE 3

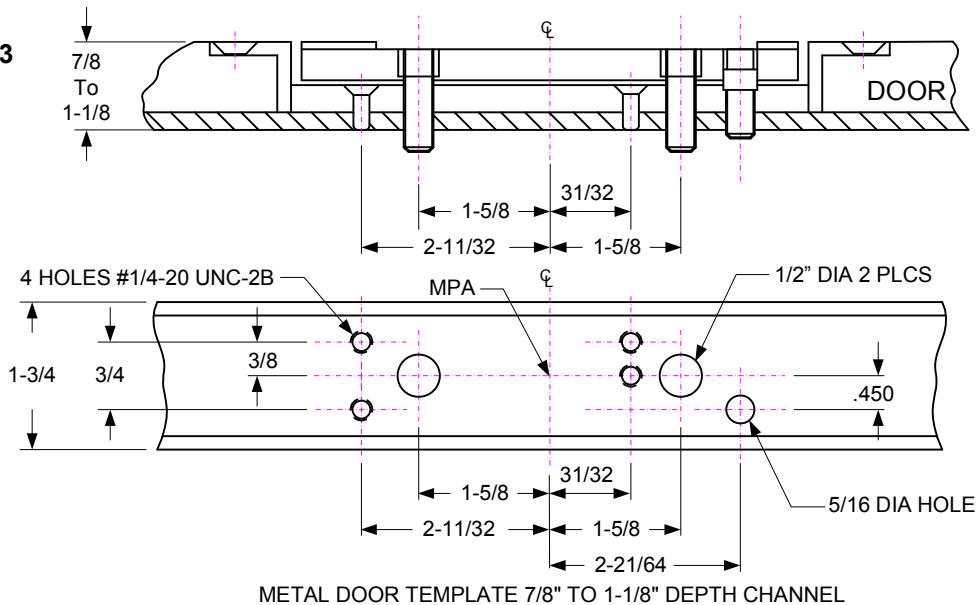

FIGURE 4

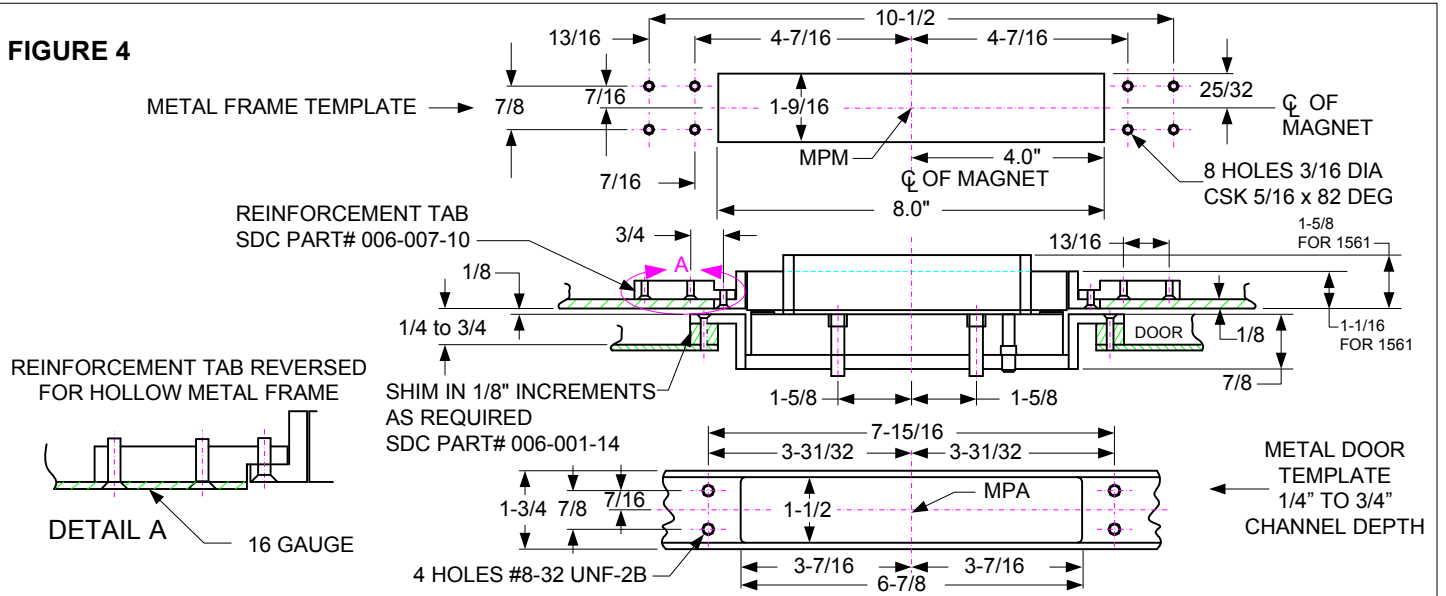

FIGURE 5

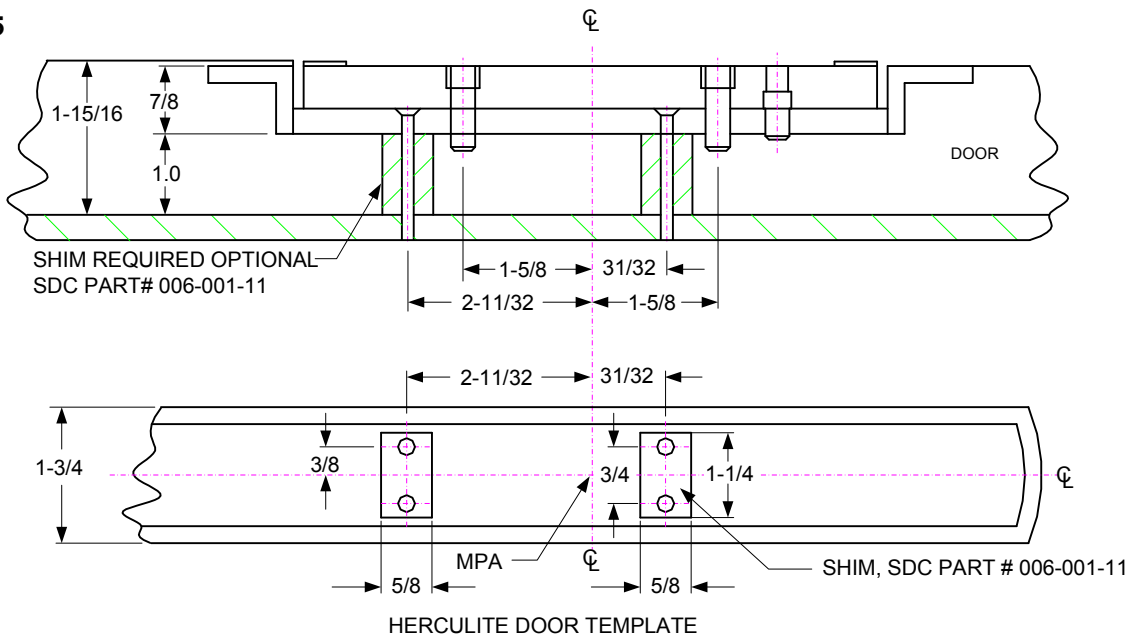

FIGURE 6

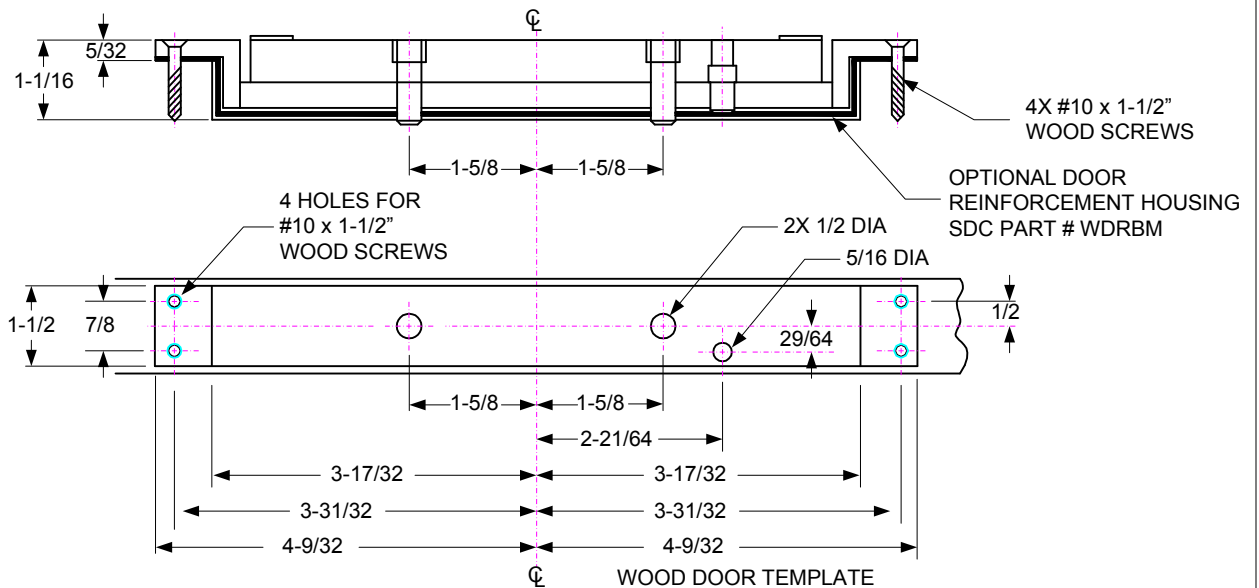

FIGURE 7

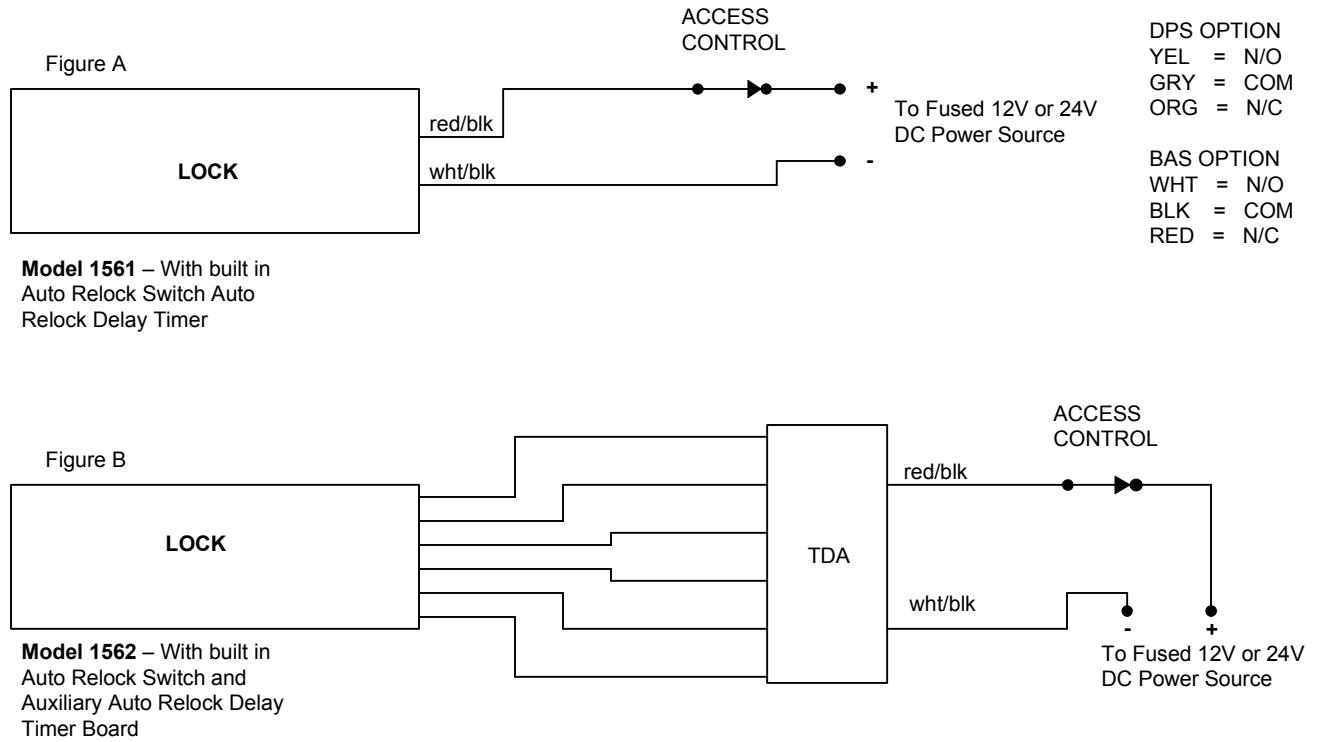

FIGURE 8

Please note the drawing in Fig. 1. It show two different alignments off center of the shear tab.

For normal single acting door alignment see Fig. 2.

For double acting doors see Fig. 6.

For slightly warped single acting doors see Fig. 4.

This also works well for quick release, when switch bars are used.

The offset shear tab cannot be used on shear locks with bond sensors. Fig 5 & 7.

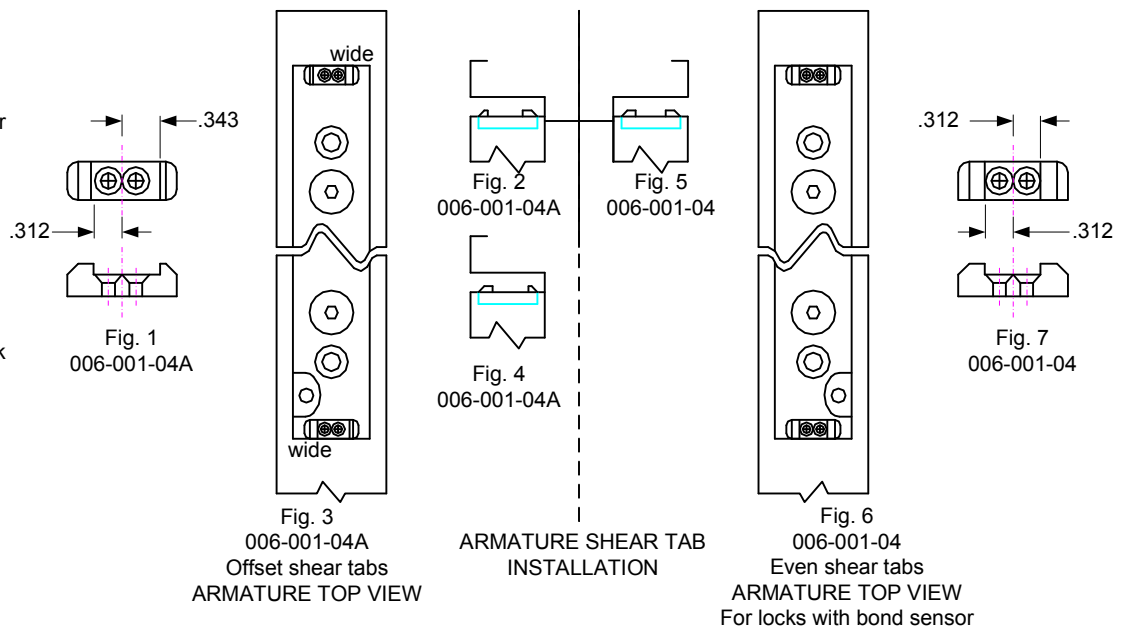

MAINTENANCE INSTRUCTIONS

The electromagnet and the armature should be handled carefully. Any damage to the surface such as paint, burrs, dirt and rust may hinder bonding of the surface and reduce holding power.

IF THE SURFACE PLATING BECOMES DAMAGED

1. Do not touch lock face with your hands.
2. Use a soft clean dry cloth or abrasive cloth (i.e., Scotch-Brite by 3M) to clean the lock face. Do not use sand paper.
3. A rust inhibitor, such as M1 manufactured by Starret, or LPS3 manufactured by LPS Laboratories (available in most hardware stores) can then be applied to the lock face.
4. Apply a coat of rust inhibitor to the armature face also.

SDC SECURITY DOOR CONTROLS

801 Avenida Acaso, Camarillo, Ca. 93012 • (805) 494-0622 • Fax: (805) 494-8861
www.sdcsecurity.com • E-mail: service@sdsecurity.com

HI-SHEAR EMLOCKS® 1565 & 1566 INSTALLATION INSTRUCTIONS

REFER TO THE PROPER TEMPLATE ACCORDING TO THE TYPE OF DOOR AND FRAME APPLICATION.

READ THESE INSTRUCTIONS AND STUDY THE TEMPLATE THOROUGHLY BEFORE BEGINNING THE INSTALLATION.

IMPORTANT NOTES:

Although electromagnetic shear locks provide the utmost in aesthetics for fail-safe applications, they are less forgiving than electric bolt locks and direct pull magnetic locks where alignment problems exist. Therefore, great care must be taken during preparation and installation of the frame, door hardware and the shear Emlock to attain proper alignment and ensure positive lock operation.

Unbalanced air conditioning (stack pressure) can hinder door alignment and must be corrected to help ensure positive locking.

HI-SHEAR EMLOCKS REQUIRE A REGULATED 12 OR 24VDC AT THE LOCK

Use only the highest quality door closer.

POSITIVE CENTERING DOOR CLOSERS ONLY should be used on double acting doors to help attain consistent dead center alignment.

Door latching problems must be corrected prior to installation.

INSTALLATION:

1. Make sure the clearance between the door top rail and frame header is 1/8". Make adjustments to the door as required.
2. Adjust single acting door and door closer to ensure the door settles immediately and is fully closed and at rest against the stop allowing for mutes, smoke seals or weather stripping where applicable.

Adjust double acting door and POSITIVE CENTERING DOOR CLOSER to ensure the door settles immediately and is fully closed and at rest in the dead center of the frame.

3. Locate the vertical centerline of the Emlock and armature as close as possible to the leading door edge.

CAUTION: Wood door applications require the armature back box to be located an ample distance from the door edge vertical grains, to avoid splitting from wood screws.

4. Determine the horizontal centerline of the door top rail thickness. The armature centerline will be the same.

Mark the door per the template.

5. Before determining the frame header centerline, single acting doors must be fully closed and at rest against the stop allowing for mutes, smoke seals or weather stripping where applicable. Double acting doors must be fully closed and at rest in the dead center of the frame.
6. Mark the frame header per the template.
7. Prepare the door and frame per the template.

Any suggestions or comments to this instruction or product are welcome. Please contact us through our website or email engineer@sdsecurity.com

8. The Hi-Shear Emlock may be wire to one of two different electrical configurations. An Auto Relock time delay (standard with the 1565) is recommended for all installations to delay relocking 1 to 6 seconds after initial door closure. This will help ensure the door is fully closed and at rest to obtain alignment before the Emlock is energized. Consult Figure 7A or 7B according to material supplied.

With the power off make all wire connections to a properly fused power source.

9. When installing 1566 model use Figure 7B, make the timer adjustment as required and test the TDA time delay prior to mounting in the frame. The TDA timer is field adjustable for 1 to 6 seconds and is factory set at approximately 3 seconds. Turn clockwise to increase and counter clockwise to decrease the delay time.

10. Install the Emlock and armature with the auto relock switch assembly towards the leading edge of the door.

11. For proper operation, the armature must be adjusted upward as close as possible and parallel to the Emlock without interfering with opening and closing of the door. Proper operation cannot be expected with more than 1/8" clearance between the armature and the Emlock. Use the hex key provided to adjust the armature vertical adjustment screw (the allen head screws centered at both ends of the armature assembly). Turn counter clockwise to raise the armature.

12. With the door closed, turn the lock power on. Check the lateral alignment. The armature shear stops should be centered between each pair of magnet shear stops.

13. If the clearance between the shear stops is sufficient, open and close the door a few times to ensure the Emlock will lock and unlock positively.

14. Adjust the auto relock switch magnet to avoid early activation and help ensure positive locking on door closure. Adjust inward to delay Emlock activation. **Do not** adjust higher than the armature rest position.

15. If the shear stops are too close or binding, double check the templating and door alignment, and make corrections as required.

16. If positive locking cannot be attained due to misalignment after the previous adjustments, the armature shear stops can be reversed with the wide clearance shear stops.

CAUTION: The use of armature offset shear stops may correct misalignment but should not be used when proper door latching is inhibited.

17. Repeat steps 11 through 15 as necessary following shear stop replacement.

18. Cycle the door and Emlock several times after the completion of installation.

MODEL #	LOCK DIMENSION			HOLDING FORCE	POWER CONSUPTION		MODEL #	ARMATURE DIMENSION		
	L	W	D		12VDC	24VDC		L	W	D
1565	10-7/116"	1-1/2"	1-5/8"	2700	800mA	400mA	ITC	11"	1-1/2"	7/8"
1566	10-7/16"	1-1/2"	1-1/4"	2700	800mA	400mA	FTC	11"	1-1/2"	7/8"
							HTC	11"	1-1/2"	7/8"

FIGURE 1

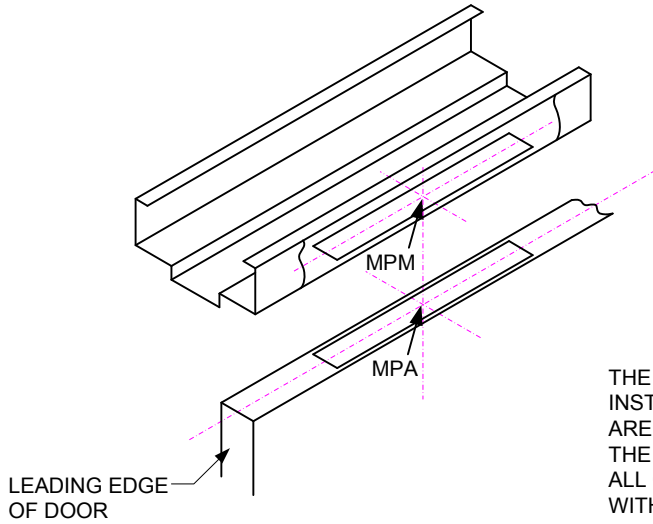

MIDPOINT IDENTIFICATION
 MPM – MIDPOINT MAGNET
 MPA – MIDPOINT ARMATURE

THE MOST IMPORTANT ELEMENTS FOR THE PROPER INSTALLATION OF THE HI/SHEAR MAGNET ASSEMBLY ARE THAT THE MIDPOINT OF THE ARMATURE AND THE MIDPOINT OF THE MAGNET MUST LINE UP EXACTLY. ALL CENTERLINES OF THE ARMATURE MUST LINE UP WITH THE RESPECTIVE CENTERLINES OF THE MAGNET

FIGURE 2

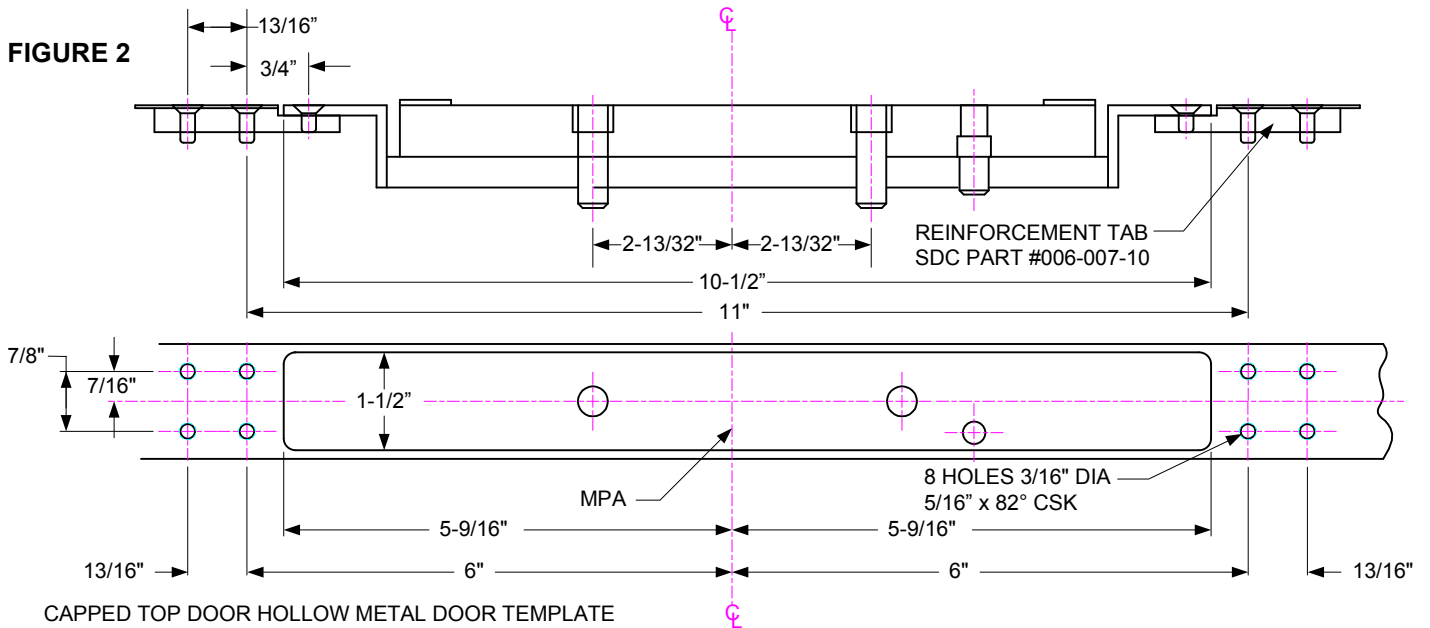

CAPPED TOP DOOR HOLLOW METAL DOOR TEMPLATE

FIGURE 3

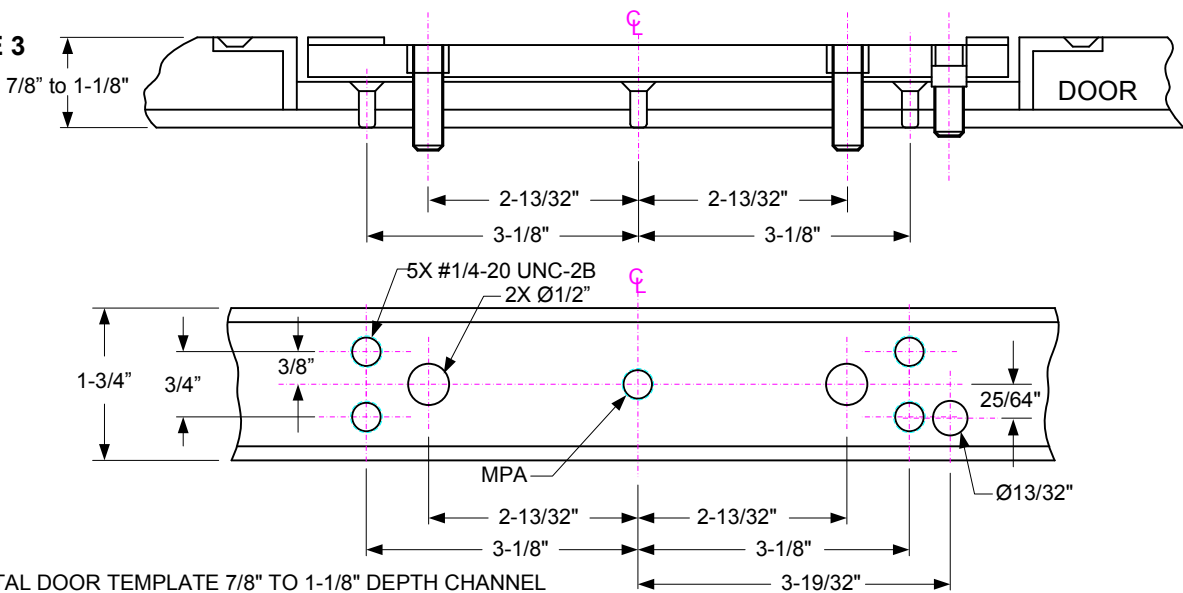

METAL DOOR TEMPLATE 7/8" TO 1-1/8" DEPTH CHANNEL

FIGURE 4

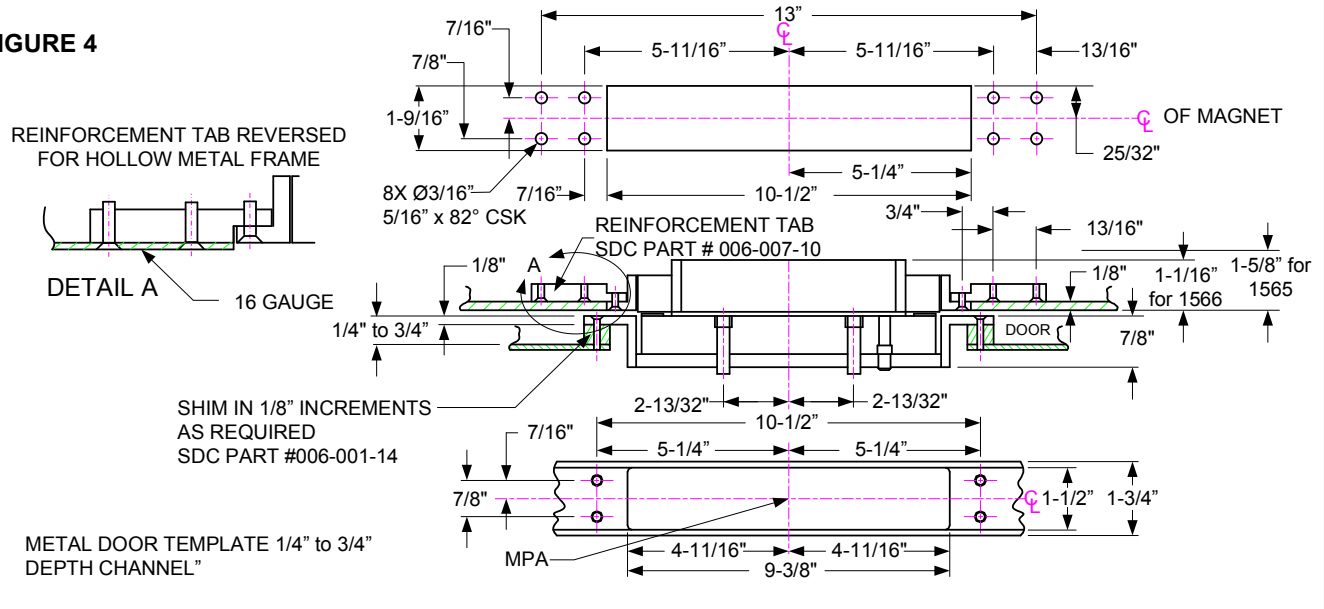

FIGURE 5

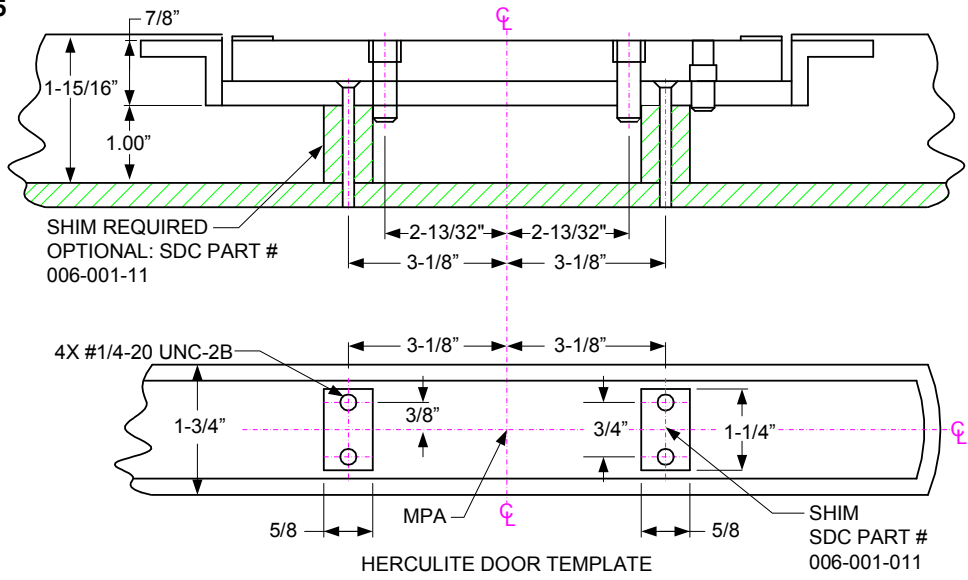

FIGURE 6

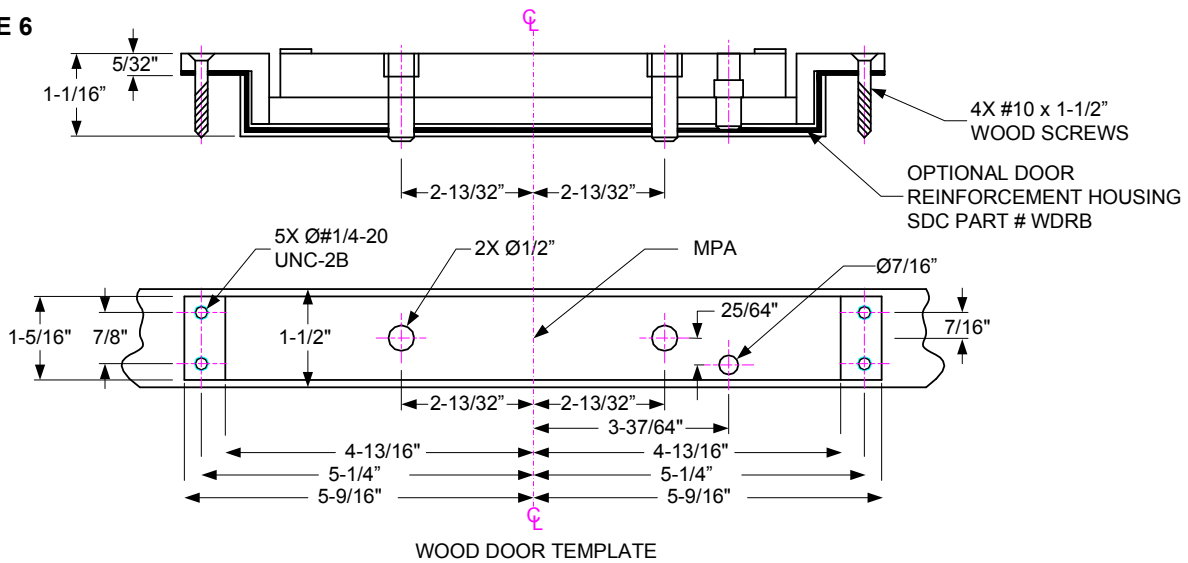

FIGURE 7

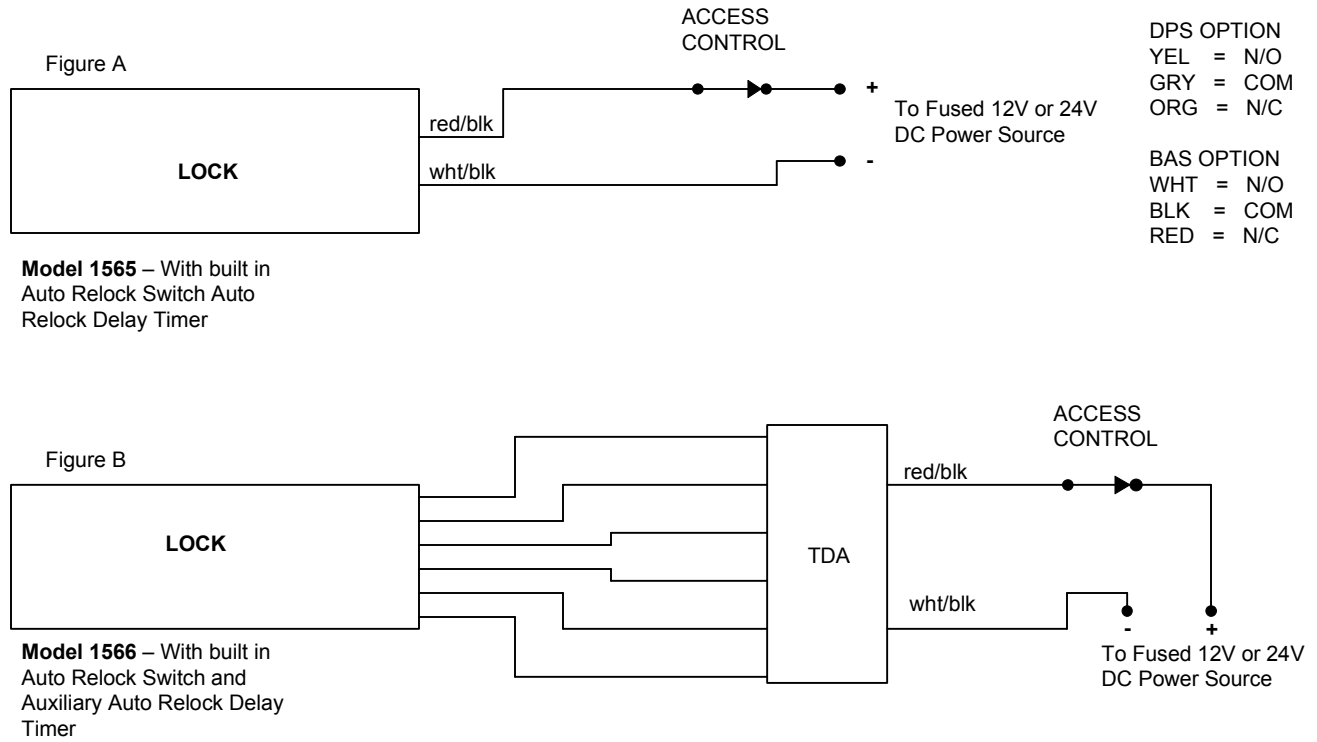

FIGURE 8

Please note the drawing in Fig. 1, shows two different alignments off center of the shear tab.

For normal single acting door alignment see Fig. 2.

For double acting doors see Fig. 6.

For slightly warped single acting doors see Fig. 4.

This also works well for quick release, when switch bars are used.

The offset shear tab cannot be used on shear locks with bond sensors. Fig 5 & 7.

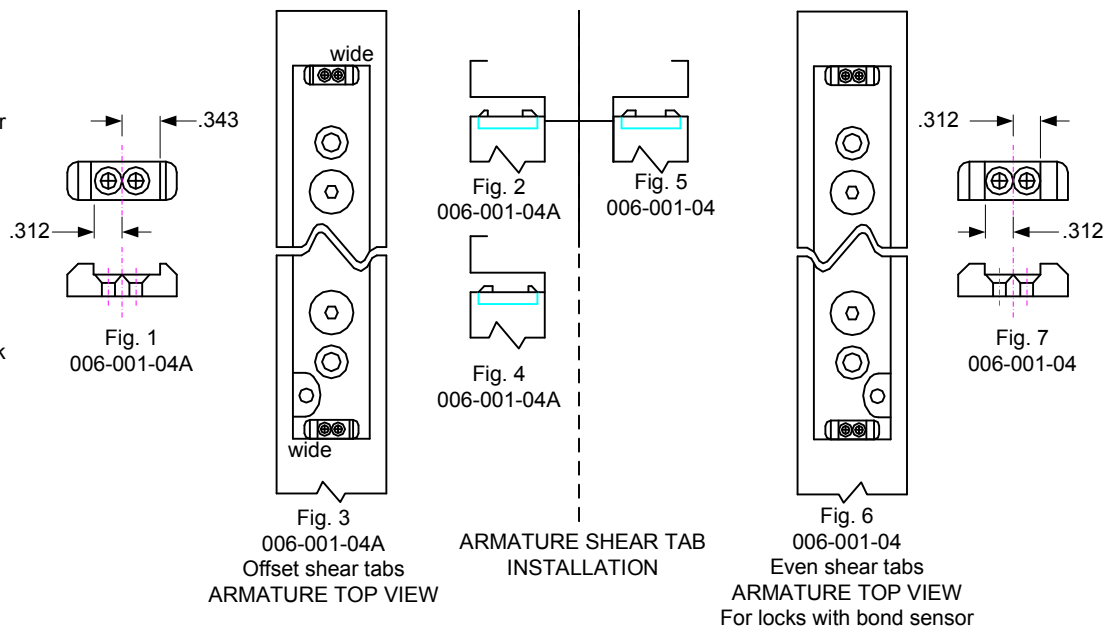

MAINTENANCE INSTRUCTIONS

The electromagnet and the armature should be handled carefully. Any damage to the surface such as paint, burrs, dirt and rust may hinder bonding of the surface and reduce holding power.

IF THE SURFACE PLATING BECOMES DAMAGED

1. Do not touch lock face with your hands.
2. Use a soft clean dry cloth or abrasive cloth (i.e., Scotch-Brite by 3M) to clean the lock face. Do not use sand paper.
3. A rust inhibitor, such as M1 manufactured by Starret, or LPS3 manufactured by LPS Laboratories (available in most hardware stores) can then be applied to the lock face.
4. Apply a coat of rust inhibitor to the armature face also.