



SECURITY DOOR CONTROLS

3580 Willow Lane, Westlake Village, CA 91361-4921 • (805) 494-0622 • Fax: (805) 494-8861
www.sdcsecurity.com • E-mail: service@sdsecurity.com

INSTALLATION INSTRUCTIONS 160, 260 SERIES GATELOK



Four electric models are available: the GL 260A is the fail-secure (PUL) model, operating on 24 VDC; GL 263A has a built-in key switch control, GL 160A is fail-safe (PL), and GL 163A has a built-in key switch control.

An adjustable automatic relock switch keeps the bolt retracted until the gate is in a closed position. A 10 Amp rated bolt position switch (BPS-GL, optional) prevents operation of the gate operator until the bolt is fully retracted. A gate position switch (DPS-GL, optional) is available to monitor whether a gate is opened or closed.

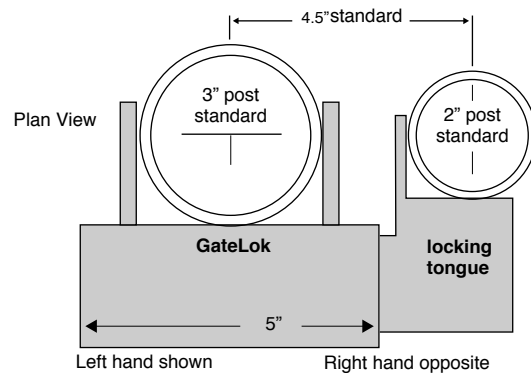

Specifications

Dimensions: Width 5", Height 6 1/8", Depth 2"

Material: 0.120" steel

Finish: Cadmium plated

Solenoid: Continuous duty

Dual Voltage (Fail Safe):

7.2 Watts - 12VDC@ .6 Amp

7.2 Watts - 24VDC@ .3 Amp

Bolt: 5/8" dia., 5/8" throw

Single Voltage (Fail Secure):

24 VDC@ .500 Amp standard

(12 VDC, 24 VAC available)

DUAL VOLTAGE SOLENOID WIRING

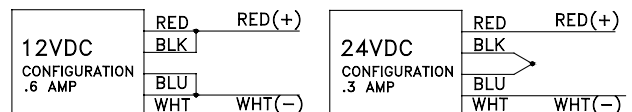

CAUTION, DO NOT PLACE LOCKING TONGUE IN LOCK UNTIL WIRING IS COMPLETE

For 160A & 260A (less key switch):

1. Remove cover and using the lock housing as a template locate and mark mounting bolt holes on the gate post. Drill through post for 2 - $\frac{3}{8}$ " hexhead bolts supplied. See Illustration 1.
2. Determine hand of gate and install Auto Relock switch and the spring loaded centering assembly in their proper locations. See illustration 2.
3. If the wiring will come in through the post, mark and drill post at lower housing hole for wiring assembly. Pull wires in through back of housing through lower hole. Be sure to shim between the mounting brackets as required if the gate post is less than 3"
4. Wire the assembly per Illustration 2 and Illustration 3. Test for proper operation.
5. Insert gate locking tongue into slot and line up tongue level on gate. Mark gate for tongue mounting bolts.
6. Remove locking tongue. Drill gate and mount locking tongue using 4 - $\frac{3}{8}$ " carriage head bolts provided. See Illustration 4.
7. Install housing cover with machine screws provided.

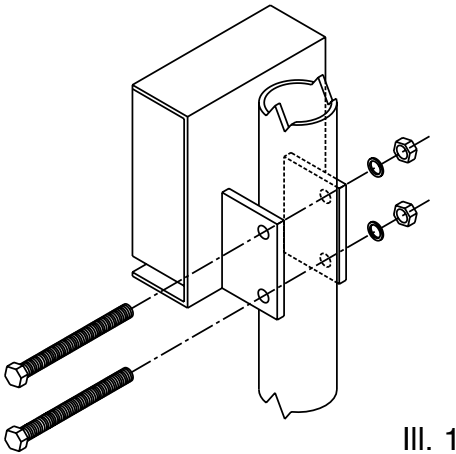

III. 1

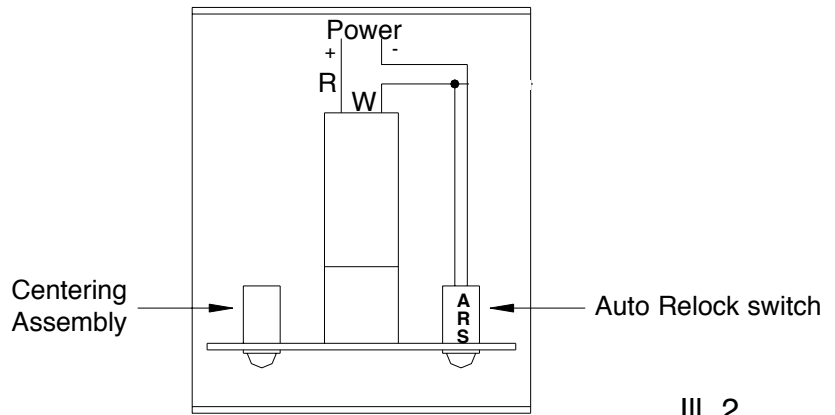

III. 2

Wiring for 200 Series Locks

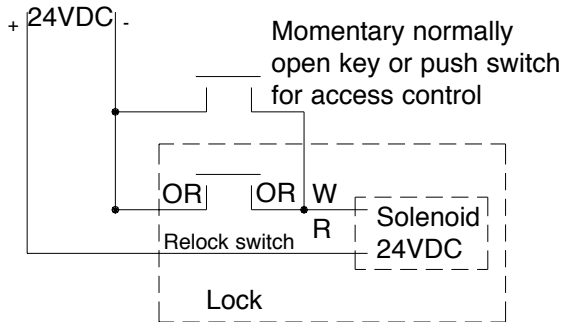

III. 3

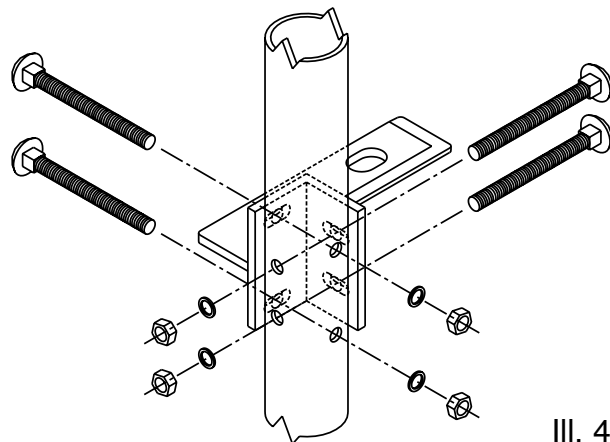

III. 4

NOTE: Sliding Gate left hand and swinging gate right hand shown in Illustrations 2 & 3. Exchange positions of centering assembly and automatic relock switch for opposite handing.

For 163A & 263A (with key switch):

Follow installation steps 1 - 3 on page 2.

4. Wire the assembly per Illustrations 5, 6, 7, 8.

- a) Cylinder must be 1 1/8" mortise type with standard tailpiece. See Illustrations 5 & 6.
- b) With key removed, remove and invert tailpiece. See Illustration 6.
- c) Key removable in "ON" or "OFF" position as determined by wiring selection. See Illustration 7.

Follow installation steps 5 - 7 on page 2.

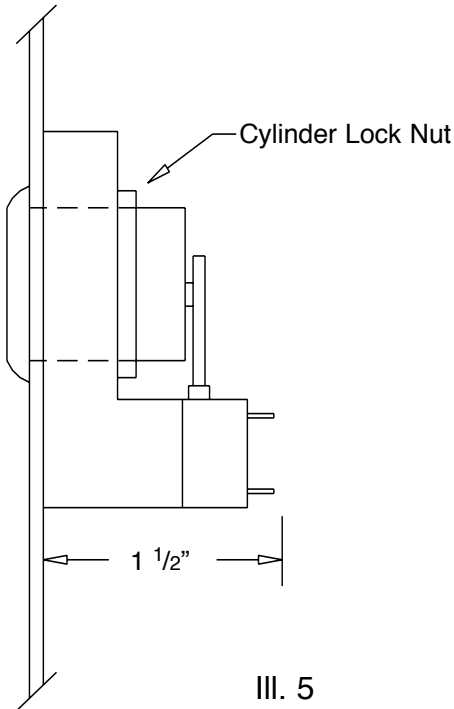

Tailpiece must depress button at all times with key removed.

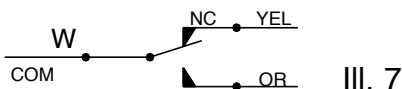
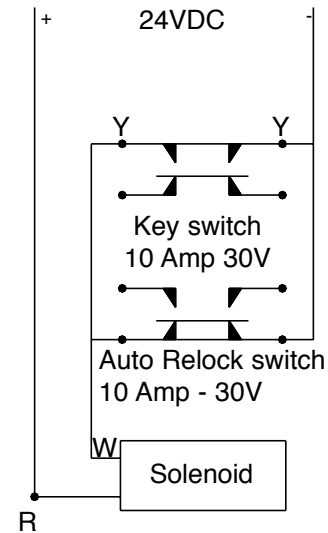
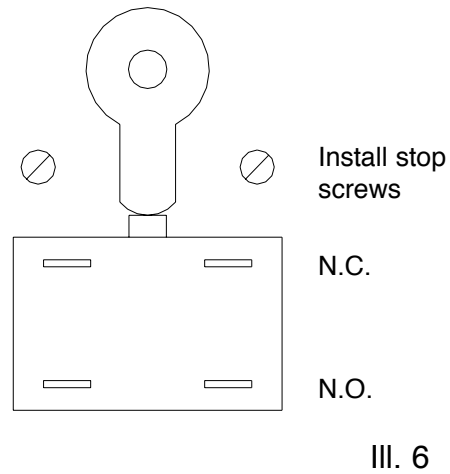

Optional bolt position switch
(BPS-GL) rated 10 Amp 30V

