



SECURITY DOOR CONTROLS

3580 Willow Lane, Westlake Village, CA 91361-4921 • (805) 494-0622 • Fax: (805) 494-8861
www.sdcsecurity.com • E-mail: service@sdsecurity.com

SPECIFICATIONS AND WIRING INSTRUCTIONS

ELECTRIC LATCH RETRACTION

S6100E RIM DEVICE
S6200E SURFACE VERTICAL
S6300E MORTISE
S6800E CONCEALED VERTICAL

ELECTRIC DOGGING

S6100G RIM DEVICE
S6200G SURFACE VERTICAL
S6300G MORTISE
S6800G CONCEALED VERTICAL

ELECTRICAL SPECIFICATIONS

VOLTAGE: 12/24 VDC

CURRENT: 12V @ 1Amp/180mA
24V @ 1Amp/180mA

ELECTRICAL SPECIFICATIONS

VOLTAGE: 12/24 VDC

CURRENT: 12V @ 180mA
24V @ 180mA

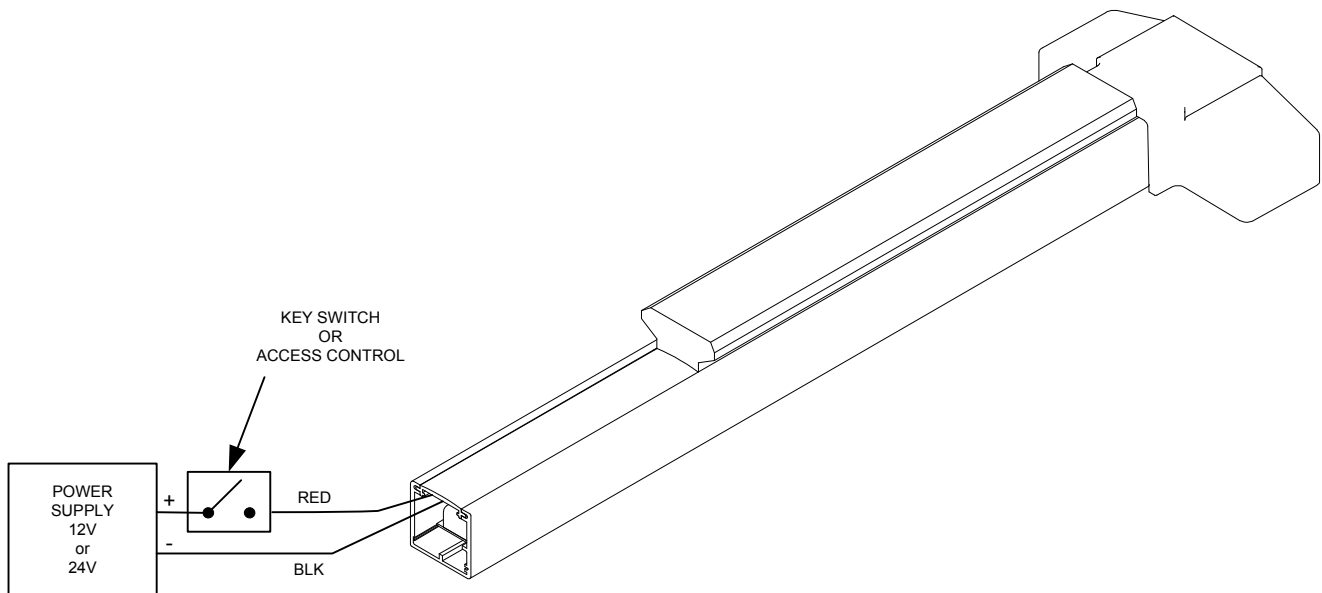

Any suggestions or comments to this instruction or product are welcome. Please contact us through our website or email engineer@sdsecurity.com