

TRIM MOUNTING HOLES:

1. Drill 7/16" dia. Thru Holes 4X

THIS SIDE UP FOR LHR DOOR

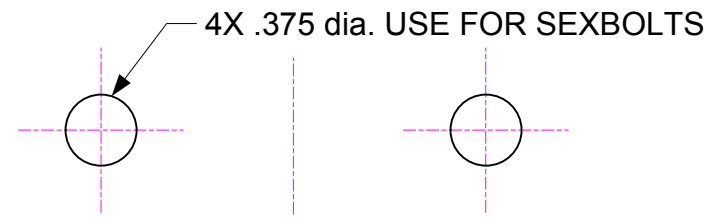

TO FACE OF STOP
2-7/16"

1/2" dia.
THRU



2-7/16"
TO FACE OF STOP



OUTSIDE

THIS SIDE UP FOR RHR DOOR

STRIKE MOUNTING HOLES:

1. Drill .201 dia. (#7 Drill) holes 2X.
2. Use #1/4-20 Tap

ADJUST THE STRIKE FOR PROPER ALIGNMENT WITH THE LATCH BOLT. LOCK STRIKE IN PLACE BY TIGHTENING THE SCREWS AT THE "X" & "Y" POSITIONS USING A 3/16" dia. DRILL. DRILL THE 3rd HOLE AT THE "Z" POSITION AND TAP WITH A #12-24 TAP. ATTACH 3rd SCREW.

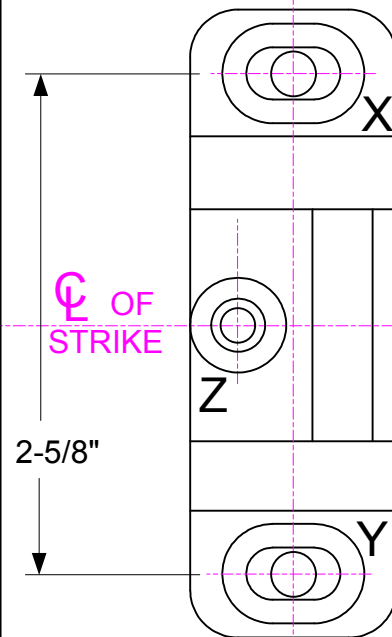

2-5/8"

CL OF STRIKE

1-3/32"

STRIKE

4X .201 dia. THRU

BACKSET 2-7/16"
TO FACE OF STOP

TO FACE OF STOP
BACKSET 2-7/16"

CL OF DEVICE

2.00"

INSIDE

INSIDE MOUNTING HOLES

For Metal Door Surface

Application:

1. Drill .201 dia. holes as marked
2. Use #1/4-20 tap.

For Sex Bolt Application:

Metal Door: .280" Drill Inside

3/8" Drill Outside

Wood Door: 3/8" Drill Thru

(Suggested to fix Device Chassis By Sex Bolt)

AFTER EXIT DEVICE IS CUT AND MOUNTED, INSTALL END CAP BRACKET CENTERED ON DEVICE CL

3-11/16"

1/2" dia.
CLEARANCE

CL OF DEVICE

.575

.594

1.188

3-11/16"

40"

Watch for special mounting height requirements

FINISHED FLOOR



Security Door Controls

801 Avenida Acaso, Camarillo, Ca. 93012

• (805) 494-0622 • Fax: (805) 494-8861

www.sdcsecurity.com

E-mail: service@sdsecurity.com

TEMPLATE-S6100

Devices covered by this template:
Panic Rim Device and Fire Rim Device.

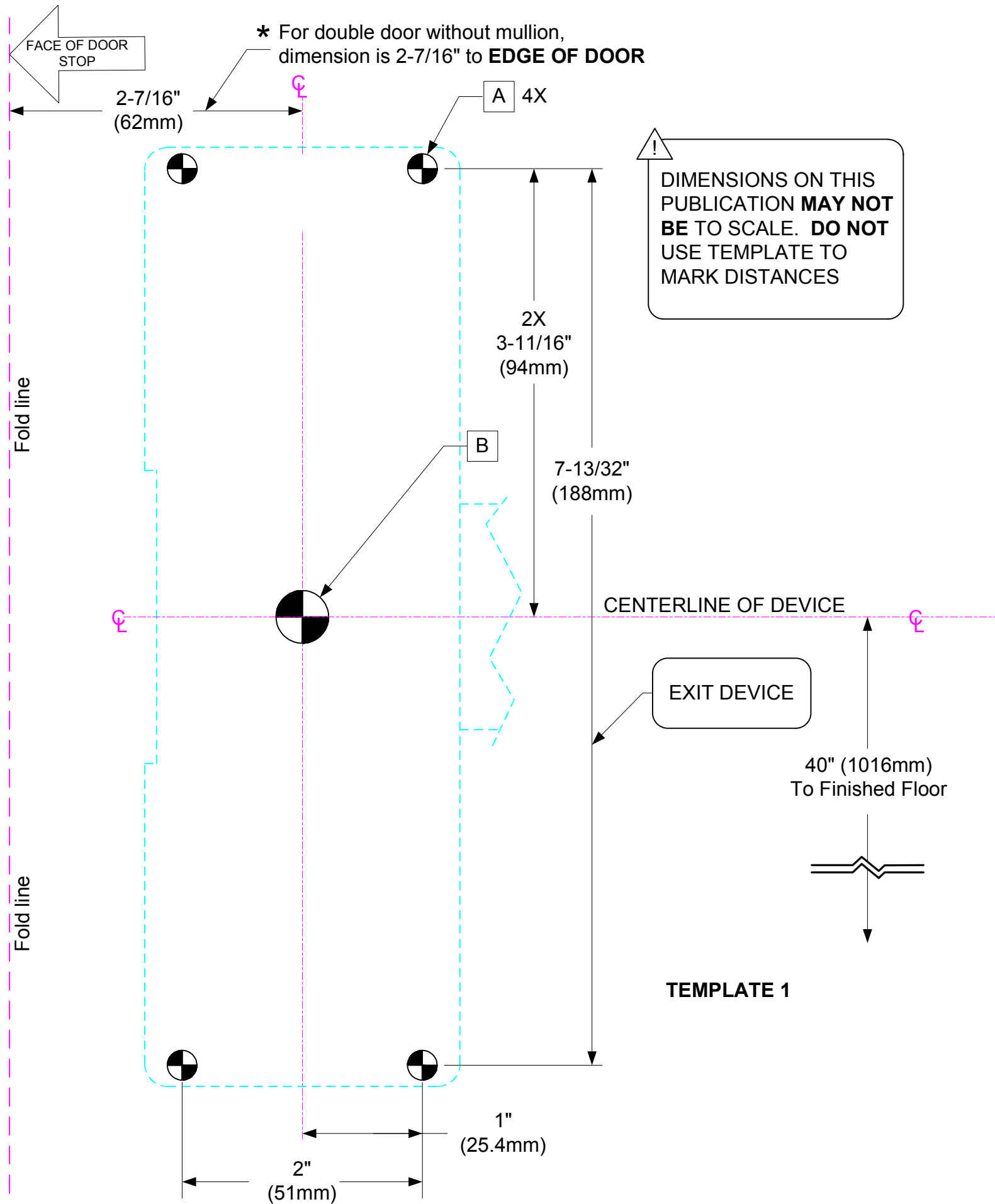

⚠ DIMENSIONS ON THIS PUBLICATION **MAY NOT BE TO SCALE. DO NOT USE TEMPLATE TO MARK DISTANCES**



801 Avenida Acaso, Camarillo, Ca. 93012
 • (805) 494-0622 • Fax: (805) 494-8861
 www.sdcsecurity.com • E-mail: service@sdsecurity.com

**TEMPLATE-S6200
 SURFACE MOUNT VERTICAL ROD**

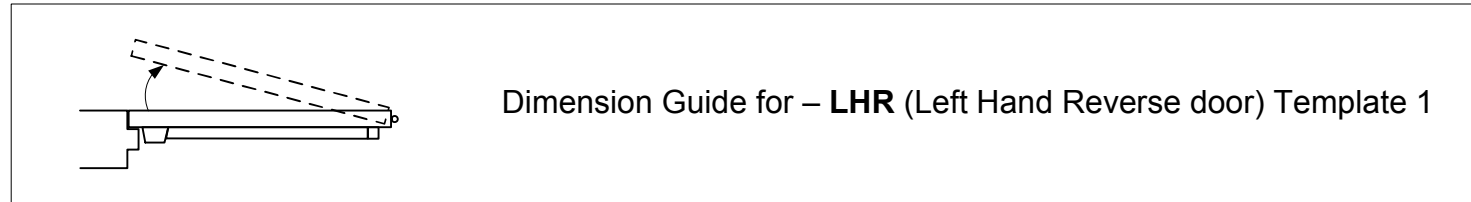

1. Draw a centerline horizontally across the door, 40" (1016mm) from bottom of door.
2. Draw a vertical centerline 2-7/16" (62mm) from edge of door.
3. Select the appropriate side of both templates. (1 & 2). Your door handing will determine the appropriate side, either **(LHR)** or **(RHR)**.
4. Using dimensions indicated on templates 1 & 2, locate and mark the center of the required holes.
5. Drill holes as indicated by their designated letter.
6. If using an exterior trim, refer to the template with trim to further prepare door.

A **METAL – Panic Rated:** Drill/Tap for 1/4-20 machine screws (sexbolts recommended).
METAL – Fire Rated: Sexbolts required.
SEXBOLTS: Drill 3/8" (9.5mm) clearance holes on Push and Pull Sides.
WOOD: Pre-Drill 1/8" (3mm) hole.

B **ACTUATING SHAFT HOLE:** Drill 1/2" thru hole.

Dimension Guide for – **RHR** (Right Hand Reverse door) Template 2

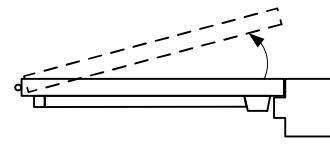

1. Draw a centerline horizontally across the door, 40" (1016mm) from bottom of door.
2. Draw a vertical centerline 2-7/16" (62mm) from edge of door.
3. Select the appropriate side of both templates. (1 & 2). Your door handing will determine the appropriate side, either (**LHR**) or (**RHR**).
4. Using dimensions indicated on templates 1 & 2, locate and mark the center of the required holes.
5. Drill holes as indicated by their designated letter.
6. If using an exterior trim, refer to the template with trim to further prepare door.

METAL – Panic Rated: Drill/Tap for 1/4-20 machine screws (sexbolts recommended).
METAL – Fire Rated: Sexbolts required.
SEXBOLTS: Drill 3/8" (9.5mm) clearance holes on Push and Pull Sides.
WOOD: Pre-Drill 1/8" (3mm) hole.

ACTUATING SHAFT HOLE: Drill 1/2" thru hole.

DIMENSIONS ON THIS PUBLICATION **MAY NOT BE TO SCALE. DO NOT USE TEMPLATE TO MARK DISTANCES**

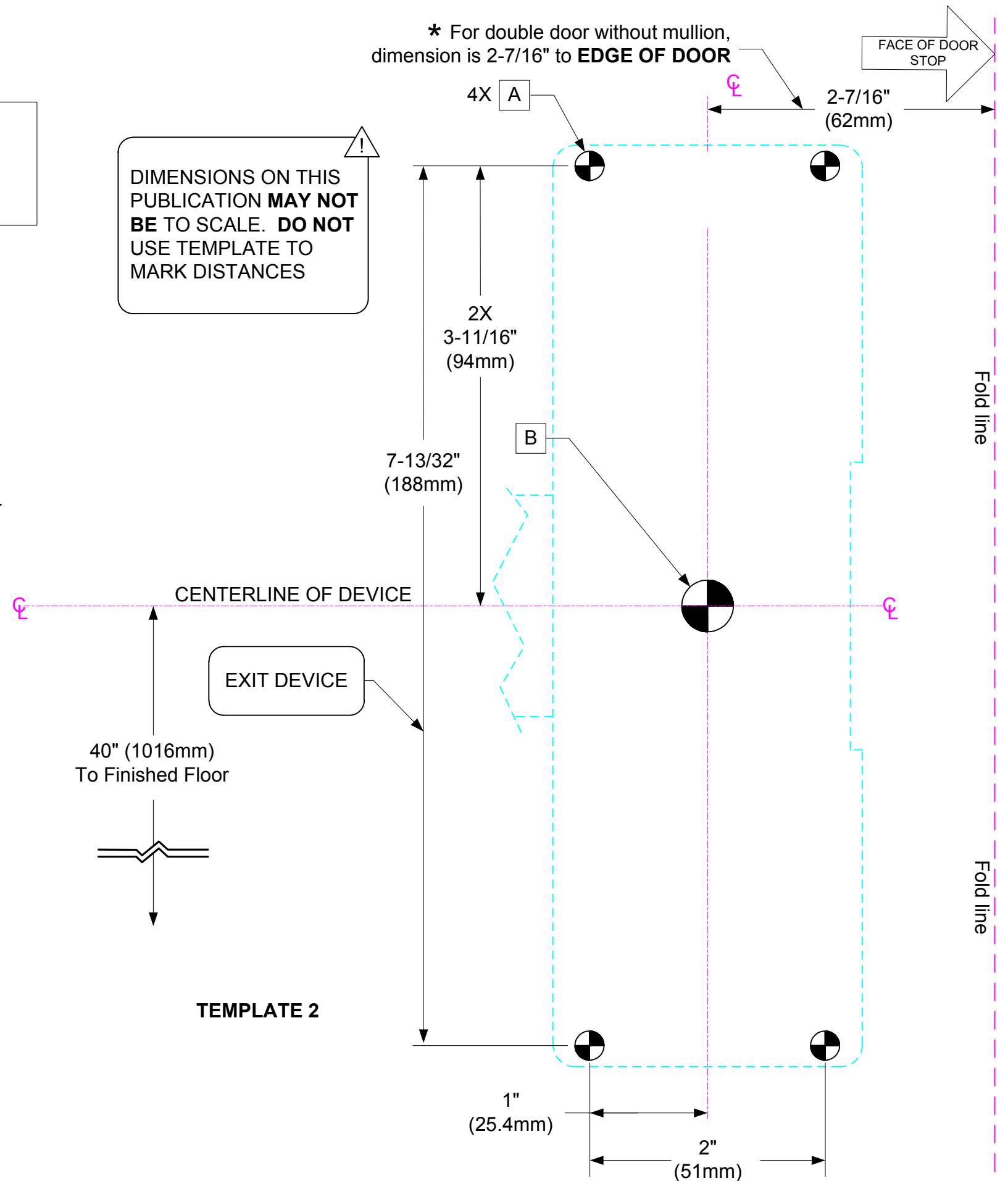

TEMPLATE-S6800 CONCEALED VERTICAL ROD

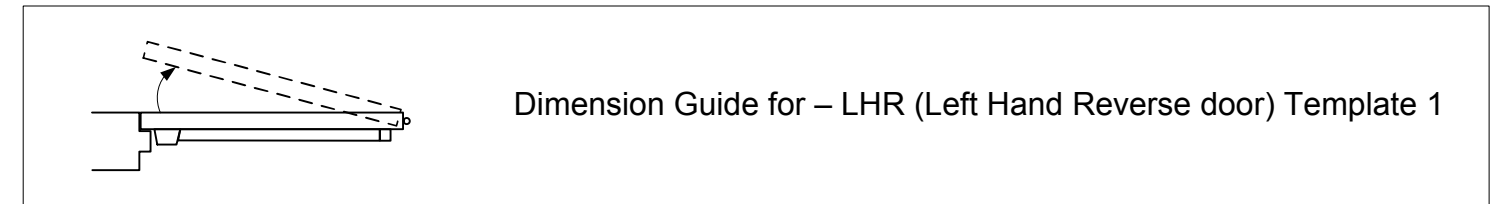

1. Draw a centerline horizontally across the door, 40" (1016mm) from bottom of door.
2. Draw a vertical centerline 2-7/16" (62mm) from edge of door.
3. Select the appropriate side of both templates. (1 & 2). Your door handing will determine the appropriate side, either **(LHR)** or **(RHR)**.
4. Using dimensions indicated on templates 1 & 2, locate and mark the center of the required holes.
5. Drill holes as indicated by their designated letter.
6. If using an exterior trim, refer to the template with trim to further prepare door.

A
METAL – Panic Rated: Drill/Tap for 1/4-20 machine screws (sexbolts recommended).
METAL – Fire Rated: Sexbolts required.
SEXBOLTS: Drill 3/8" (9.5mm) clearance holes on Push and Pull Sides.

B
ACTUATING SHAFT HOLE: Drill 1/2" thru hole.

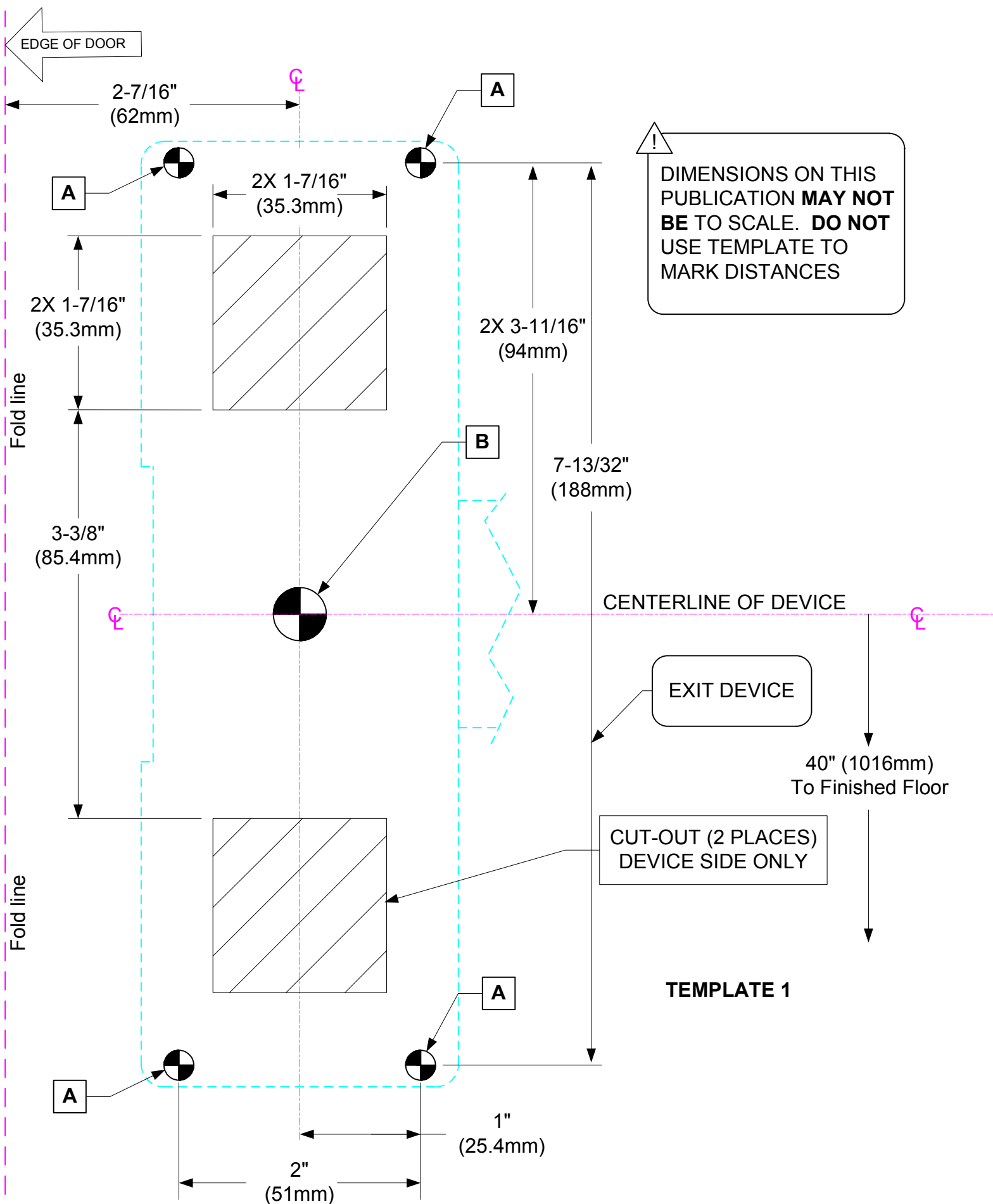

Dimension Guide for – RHR (Right Hand Reverse door) Template 2

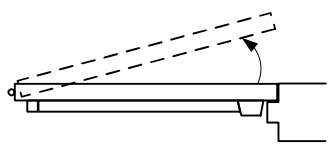

1. Draw a centerline horizontally across the door, 40" (1016mm) from bottom of door.
2. Draw a vertical centerline 2-7/16" (62mm) from edge of door.
3. Select the appropriate side of both templates. (1 & 2). Your door handing will determine the appropriate side, either (LHR) or (RHR).
4. Using dimensions indicated on templates 1 & 2, locate and mark the center of the required holes.
5. Drill holes as indicated by their designated letter.
6. If using an exterior trim, refer to the template with trim to further prepare door.

A
METAL – Panic Rated: Drill/Tap for 1/4-20 machine screws (sexbolts recommended).
METAL – Fire Rated: Sexbolts required.
SEXBOLTS: Drill 3/8" (9.5mm) clearance holes on Push and Pull Sides.

B
ACTUATING SHAFT HOLE: Drill 1/2" thru hole.

! DIMENSIONS ON THIS PUBLICATION **MAY NOT BE TO SCALE. DO NOT USE TEMPLATE TO MARK DISTANCES**

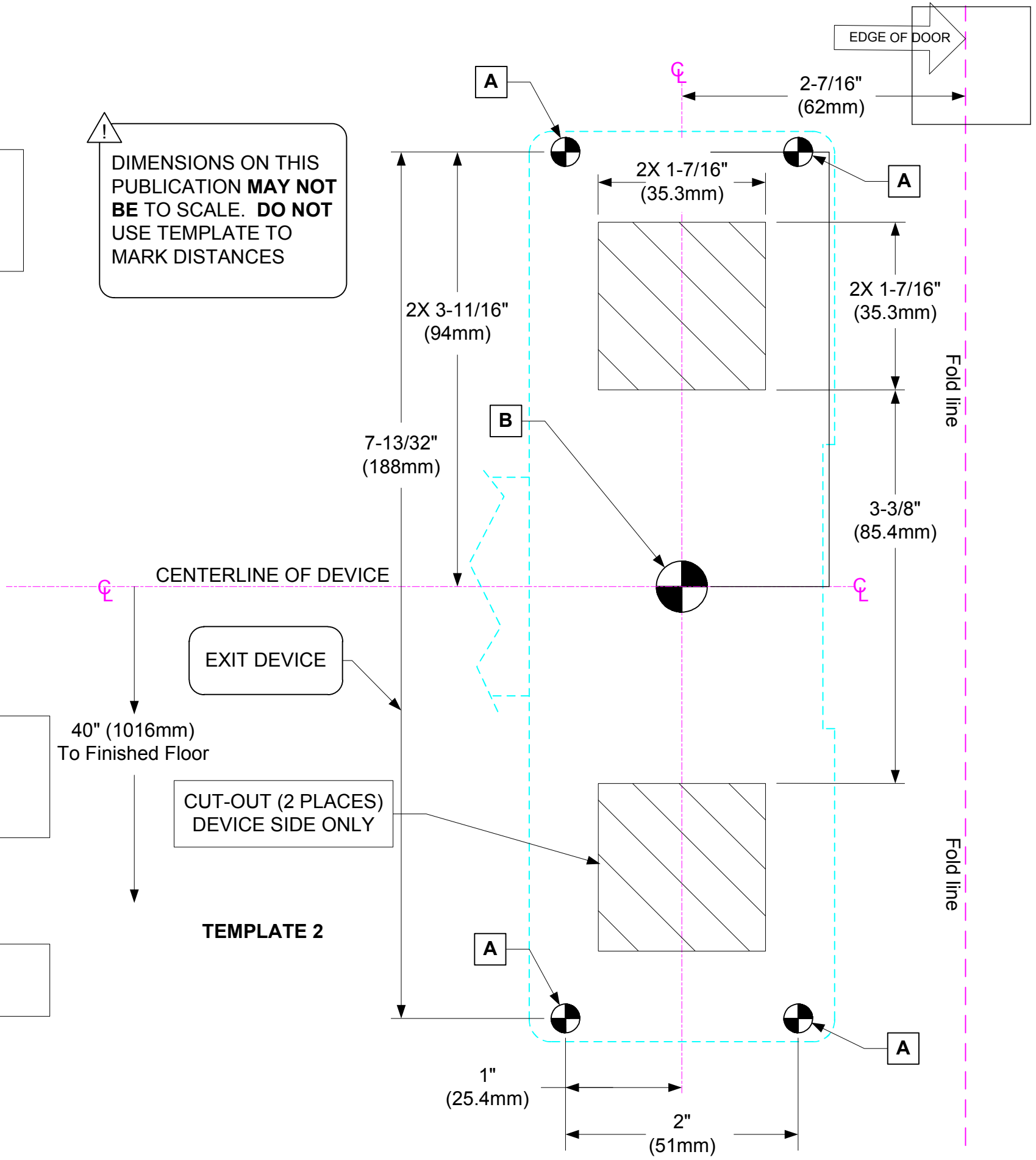

Top Door Frame

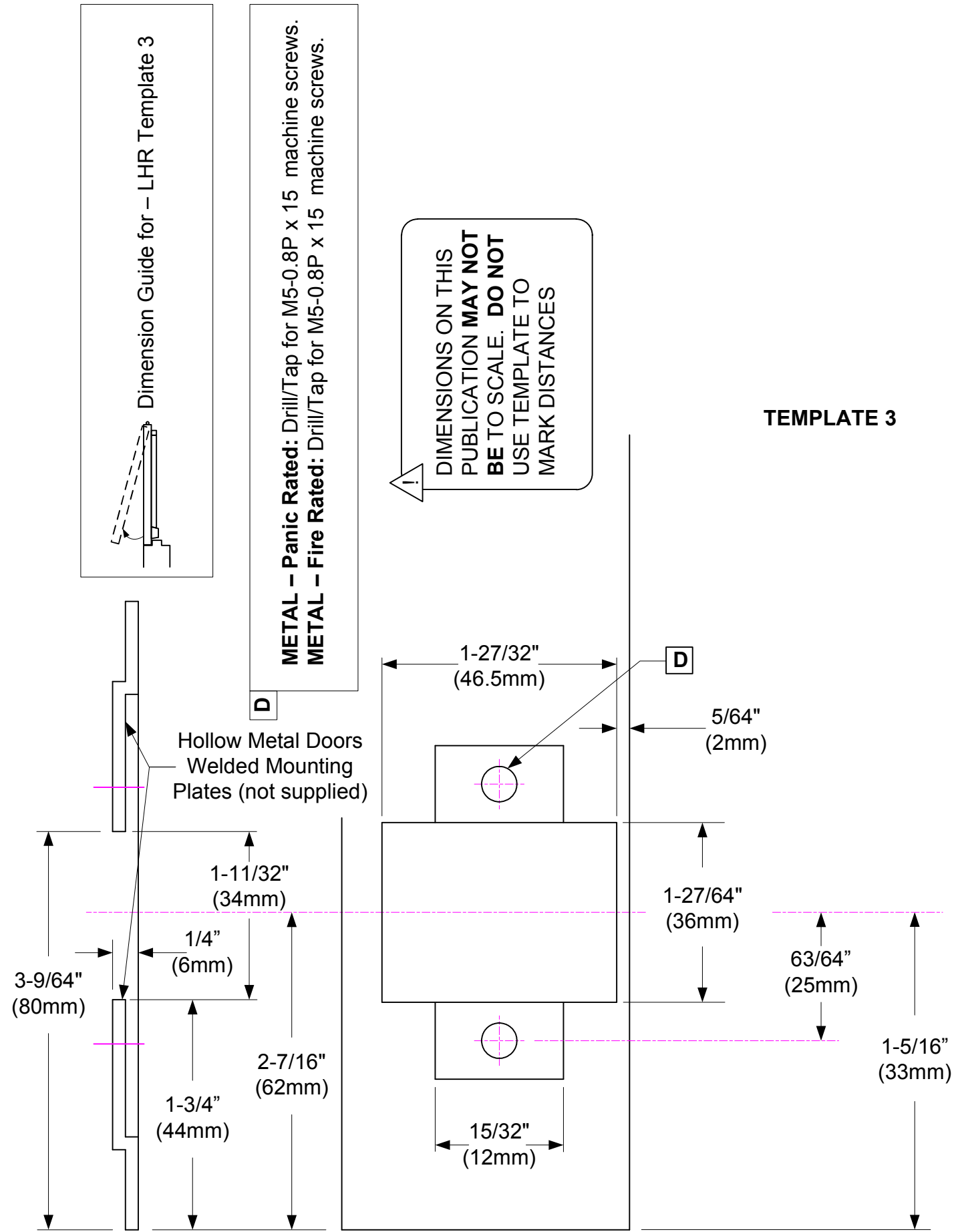

Top Edge of Door

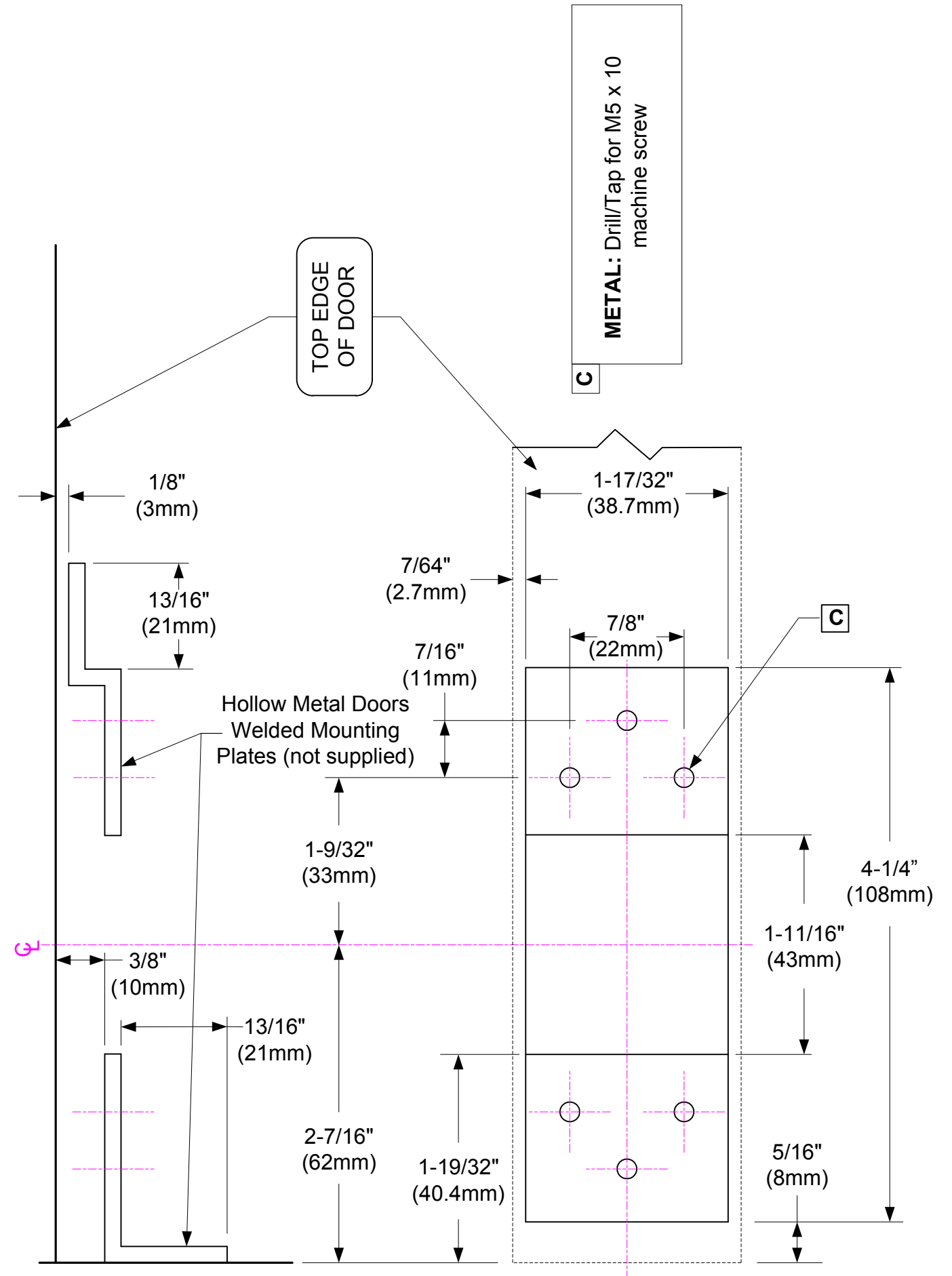

Top Door Frame

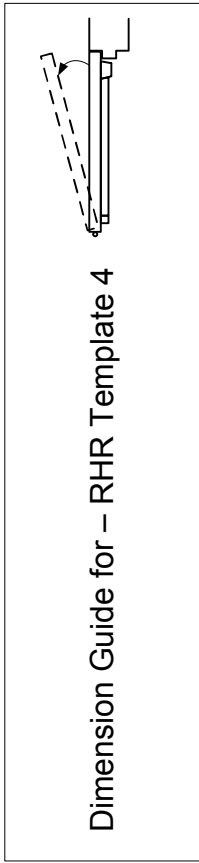
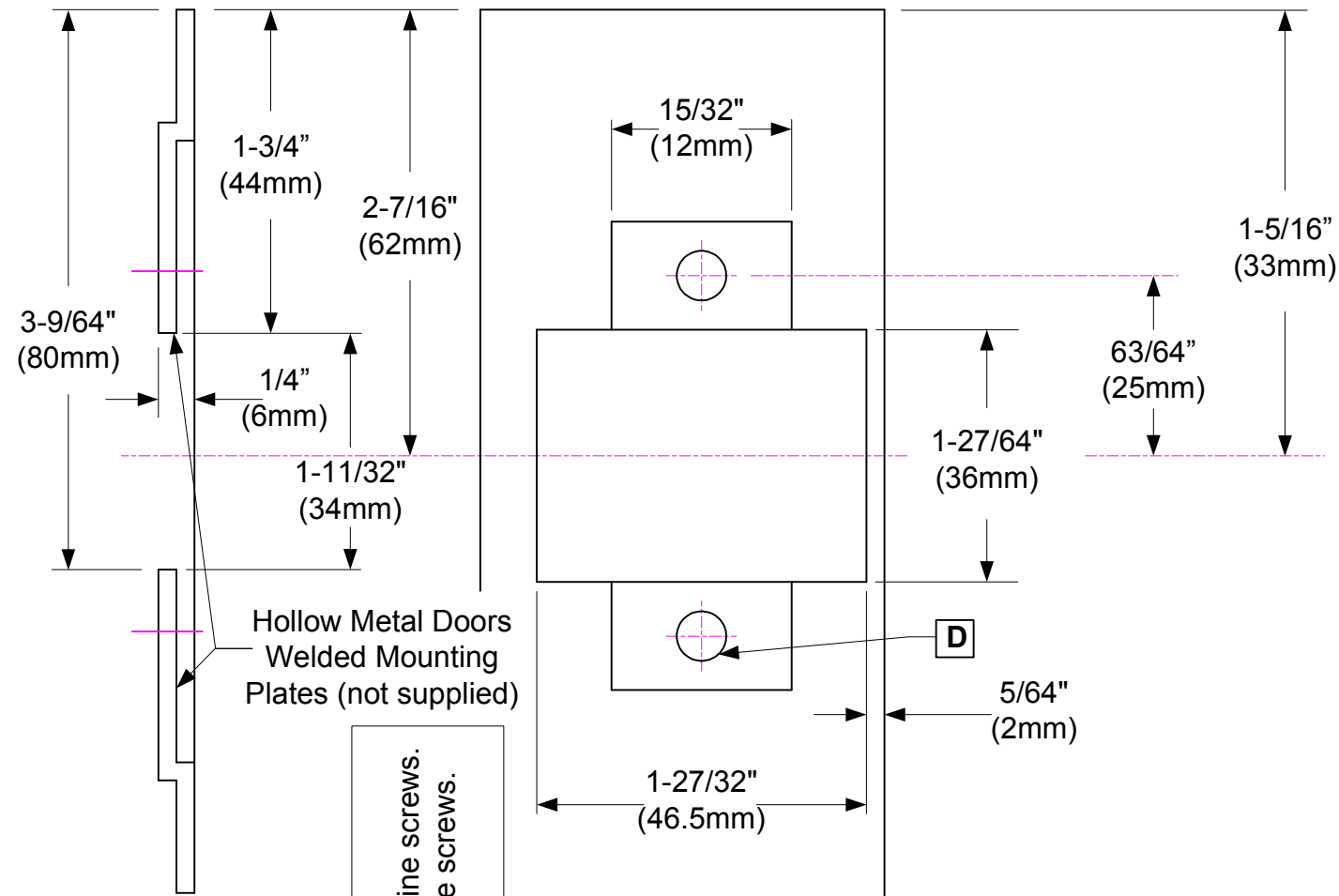

D
METAL – Panic Rated: Drill/Tap for M5-0.8P x 15 machine screws.
METAL – Fire Rated: Drill/Tap for M5-0.8P x 15 machine screws.

! DIMENSIONS ON THIS PUBLICATION MAY NOT BE TO SCALE. DO NOT USE TEMPLATE TO MARK DISTANCES

TEMPLATE 4

Top Edge of Door

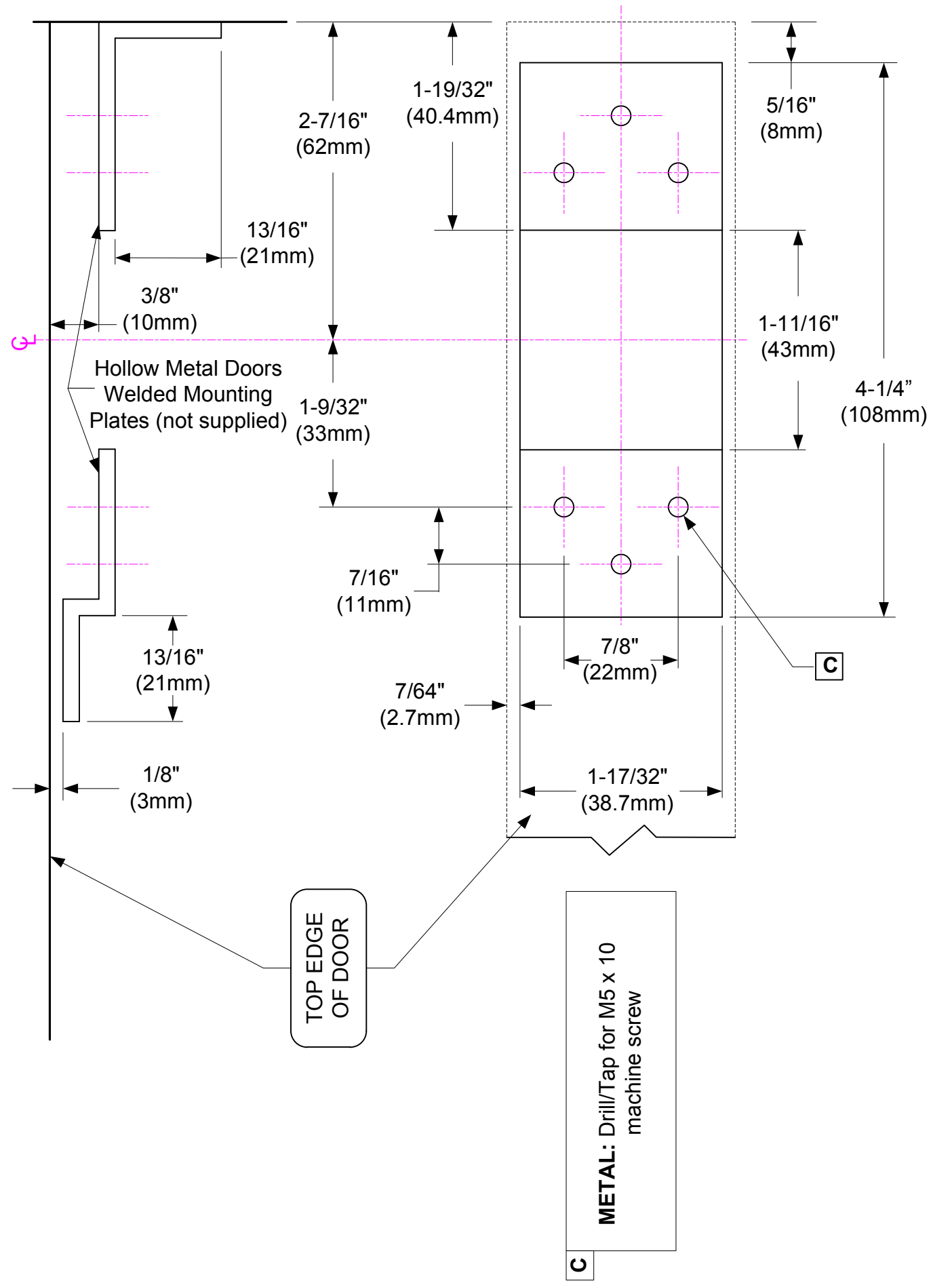

TOP EDGE OF DOOR

C
METAL: Drill/Tap for M5 x 10 machine screw

