



www.sdcsecurity.com service@sdsecurity.com  
 [t] 800.413.8783 805.494.0622 [f] 805.494.8681  
 801 Avenida Acaso, Camarillo CA 93012 • PO Box 3670, Camarillo CA 93011-3670

www.SDCsecurity.com

# White Papers: Magnetic Locks



Chapter 1 - Page 2

## THE FOUNDATION OF MAGNETIC LOCK DESIGN AND APPLICATION

Chapter 2 - Page 3

## HOLDING FORCE SECURITY & APPLICATION

Chapter 3 - Page 5

## ESSENTIAL DESIGN AND INSTALLATION ATTRIBUTES

Chapter 4 - Page 7

## ESSENTIAL LISTING AND PERFORMANCE CERTIFICATION

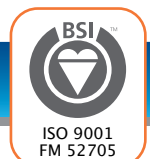

# THE FOUNDATION OF MAGNETIC LOCK DESIGN AND APPLICATION

By Richard Geringer, V.P. Marketing

**May 15, 2007** — Prior to the 1970's it was illegal to lock perimeter exit doors from the interior side. In fact, all that was permitted in most commercial buildings was an exit device to insure uninhibited egress at all times while locked on the exterior. This was problematic in that the exit devices left facilities vulnerable to employee theft and also to breaking and entering simply by using a clothes hanger to manipulate and unlock the exit device from the



Figure 1



© Copyright 2007, Security Door Controls

exterior. Still, most jurisdictions would not permit electromechanical locking due to fire life safety issues. For these reasons many facility owners, including commercial buildings, industrial facilities, banquet facilities, warehouse and convention centers, resorted to the illegal use of chains and padlocks to secure their perimeter doors after hours. To prevent employee theft, breaking and entering, and provide life safety, a solution was needed.

While it was obvious an electric lock connected to the fire command center was required, the AHJ's concern was that electromechanical locks had the potential to bind and inhibit safe egress. In 1969, Art Geringer, founder of SDC traveled to Sacramento to visit the California State Fire Marshal.

There, the fire marshal indicated that he would approve a lock that did not rely on a spring to retract the bolt and that the lock must pass a test of 800,000 cycles. Arthur returned home and designed a lock that met the state fire marshals criteria and approval. In 1971, SDC introduced the FS23M dual-failsafe bolt lock with features that helped ensure safe lock release. Still used today, the SDC bolt lock is listed for use by the California State Fire Marshal, City of New York MEA and City of Los Angeles.

- Also in 1969, Locknetics founder Irving Saphirstein, designed the first electromagnetic lock that found approval for locking perimeter doors after business hours (See Figure 1). Unlike an electromechanical lock, the electromagnet lock had no moving parts to bind or wear, making it ideal for fire life safety applications that require the assurance of trouble-free release during normal operation, a power outage or by a signal from the fire life safety system (see figure 2). However it took a while for this concept to be accepted by distributors for several reasons. It required a lot of current, had low holding force and required a special

power supply to eliminate residual magnetism. Eventually improvements were made to eliminate these issues and several more companies, including SDC, began manufacturing electromagnetic locks.

Initially intended for securing perimeter doors after business hours, the simplicity of EMLock® installation made it popular for many other applications, even those for which it is not permitted by code, such

Figure 2

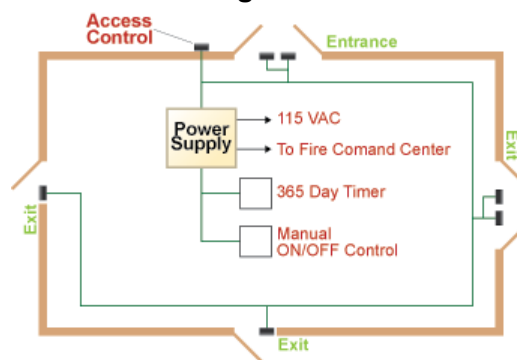

© Copyright 2007, Security Door Controls

as elevator lobby doors and high-rise stairwell doors, or the locking of entrance doors during business hours. However, only failsafe electrified locksets or electrified exit devices meet code criteria for the access control of stairwell doors or exit doors during business hours. Unlike magnetic locks, these locking devices provide uninhibited egress by manual means only.

# HOLDING FORCE - SECURITY & APPLICATION

By Richard Geringer, V.P. Marketing

July 17, 2007

## EMLock® - Security Levels

Because of the use of electromagnetic locks for many access control applications, careful concern should be given to choice of holding force and the need for battery back up. The SDC EMLock® Series is available in different holding force and design configurations to accommodate several different applications.

Model	Holding Force	Configuration	Security Level
1581	650lbs	Surface Mount	Traffic Control
1571	1200lbs	Surface Mount	Medium Security
1511	1650lbs	Surface Mount	High Security
1561	2000lbs	HiShear Concealed or Surface Mount	High Security
1565	2700lbs	HiShear Concealed or Surface Mount	High Security

## Battery Backup

Battery backup is recommended to compensate for the inherent failsafe operation in applications with higher security requirements, particularly on interior doors. When installed on perimeter doors, building and safety codes require magnetic locks to release during a building power loss and signal from the life safety system command center.

## Surface Mount EMLock® Application

### Traffic Control

Any magnetic lock with a holding force less than 1200 lbs. should only be used for traffic control, as would a light or medium duty electric strike. A holding force of 650 lbs (see figure 3) is typical for most magnetic locks fit for traffic control and they may be easily defeated. However, this is a benefit compared to the use of light duty electric strikes. As the electric strike may break when forced, a low holding force magnetic lock will release without damage and the door will simply relock when closed.

### Medium Security

Magnetic locks mounted on an aluminum glass door are capable of providing medium security because the glass door is more likely to shatter before a lock with 1200 lbs. (see figure 3) of holding force will release. For this reason, a lock with 1200 lbs. of holding force is sufficient for



aluminum and glass openings and many commercial interior installations where aggressive attacks are not expected, such as openings made of metal frames and wood or hollow metal doors..

## High Security

It is important to note that the term 'high security' is used only in the context of a failsafe magnetic door lock application, which cannot compare to the integrity provided by electromechanical locking devices, such as failsafe and failsecure electrified locksets, electric deadbolts or heavy-duty electric strikes.

For most commercial and industrial high security applications with Herculite glass doors or hollow metal frames with wood or hollow metal doors, an electromagnetic door lock with at least 1500 lbs. (see figure 3) of holding force is recommended. When attacked with extreme force, these doors may not release, but may sustain damage.

While many installers may feel that 1200 lbs. of holding force is ample for any installation, it must be noted, that when these locks are overcome with force, the door will simply close and relock, with no one the wiser about the security breach.

For example, in psychiatric facilities, aggressive patients have been known to force open doors equipped with 1200 lbs. holding force magnetic locks. It is not uncommon for some facilities to upgrade to a 1650 lbs holding force EMLock® after experiencing more than one breach.

Continued on Page 4

## White Papers: Magnetic Locks, Chapter 2

### Concealed HiShear – Application

HiShear magnetic shear locks (see figure 4) are generally used for openings that require an architecturally superior appearance. When installed on openings with hollow metal frames and wood or hollow metal doors, a magnetic shear lock with a holding force of 2000 lbs. or more is capable of withstanding a force that will deform or destroy the door beyond repair before it is released. However, when installed on glass doors, the contact point between the armature and magnetic lock will be exposed to tampering on both sides of the opening.

Shear locks have more critical alignment issues than typical surface mount magnetic locks. A valuable tip for trouble free shear lock installation is the use of a Positive Centering or Heavy Duty door closer for double acting aluminum glass and Herculite doors. Standard duty double acting door closers may tend to swing back and forth before resting and eventually become misaligned, requiring frequent adjustment servicing. To eliminate this problem, the installation of a heavy duty closer causes the doors to quickly rest in the center position and greatly reduce service calls. This is something that can be installed easily by most locksmiths or door professionals.

### Semi-Concealed HiShear – Application

Semi Concealed HiShear magnetic locks (see figure 5) accommodate offset hung glass doors, plus they provide a high security alternative to standard surface mount magnetic locks when used on hollow metal frames with wood or hollow metal doors. At the same time, it still provides superior appearance while the magnet is concealed in the frame and only the small armature housing is surface mounted to the top of the door.

### Surface Mount HiShear – Application

Almost half the size of a typical surface mount EMLock®, surface mount HiShear magnetic locks (see figure 6) provide a higher level of security for glass doors or metal door and frames.

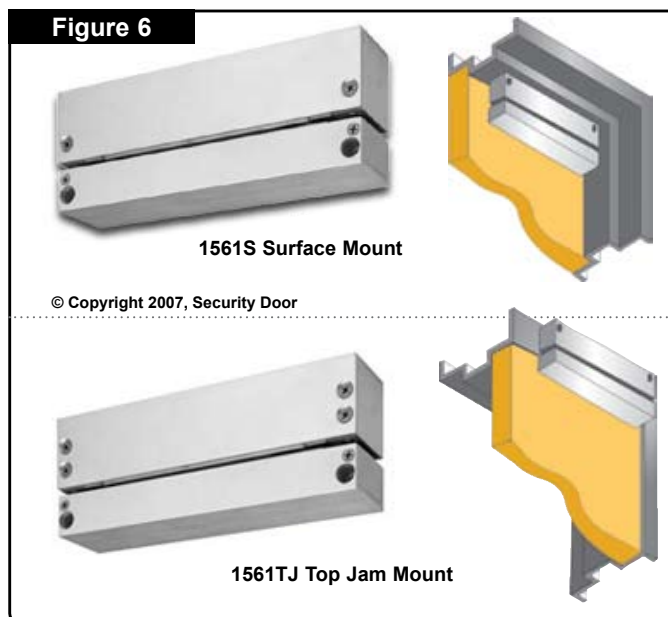
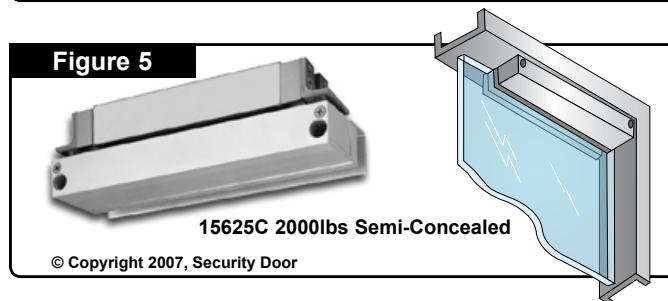
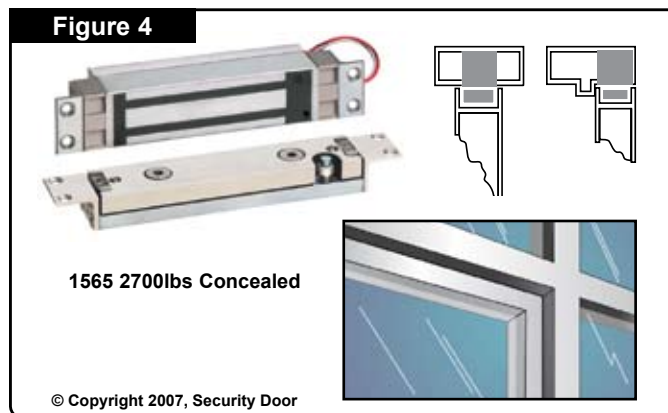

# ESSENTIAL DESIGN AND INSTALLATION ATTRIBUTES

By Richard Geringer, V.P. Marketing

August 15, 2007

Distributors, installers and end users have different priorities concerning magnetic lock design attributes. Presently, many magnetic locks on the market do not meet the requirements of all parties in the market chain. While recent installer surveys show they install one particular brand more often, many prefer to install a different brand. A lock the distributor prefers to sell or that is specified may be more difficult and time consuming to install, and these additional costs are passed on to the end user. Or, end users may not be particularly happy with a lock that looks like an extra large black brick hanging from the frame.

## Surface Mount EMLock®

When choosing a lock, look for magnetic locks that have easy mount features and do not require special tools, special nuts, and mounting hardware that may increase installation labor and service costs. The SDC EMLock 1500 series includes interlocking and adjustable quick mount assemblies, captive mounting screws, and internal wire connection that enable fast and easy installation and troubleshooting (see **Figure 6**). Wires may be pulled before or after magnetic lock mounting. SDC also provides self-drilling and self-tapping mounting screws. These installation attributes can save up to 20 minutes installation time per lock compared to sealed magnets without wire access that require special mounting hardware and screws. This adds up to the savings of a full day's labor when installing 25 locks.

## Superior Appearance

The SDC Emlock design is ideal for end users concerned with aesthetics. All sides of the housing have either an anodized or plated finish without the usual unsightly black epoxy. Plus the elimination of black epoxy eliminates the potential for toxic fumes in a fire.

## Lifetime Warranty

SDC magnetic locks are backed by the EMLock Lifetime Warranty.

## Upgrade Capability without Removing the Lock from the Frame

While service requirements are rare for electromagnetic locks, it is inconvenient when a single internal part, including optional monitoring contact, timer or coil requires upgrade or service. If you have a replacement warranty, you must still contend with the inconvenience of ordering, shipping time, and



1511 1650 lbs  
1571 1200 lbs  
1581 650 lbs

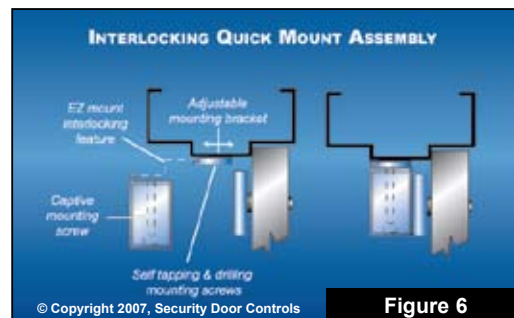

Figure 6



Figure 7

installation of the replacement lock. While the lock itself is no charge, there is still the cost of labor to remove the old lock and install its replacement.

Even better than a lock replacement warranty, is a modular EmLock that is completely upgradeable and serviceable without being removed from the frame (see **Figure 7**). This provides a quick and economical solution to unserviceable locks. Use of interchangeable modules for field upgrades and service eliminate all issues associated with lock delivery, labor, and replacement costs.

## Modular EZ Upgrade Kits (see **Figure 8**, page 2)

SDC surface mount EmLock's are field upgradeable by distributors, installers and maintenance staff. Modular Upgrade Kits include:

- Relock Delay Timer
- Magnetic Bond Sensor
- Door Status Sensor
- Anti-Tamper Switch
- Holding Force Upgrade  
(exchange 1200 lb coil with 1650 lb holding force coil)
- Energy Saver Upgrade  
(exchange 8.4 Watt, 1650 lb coil with 3 Watt, 1200 lb holding force coil)

Continued on Page 6

## White Papers: Magnetic Locks, Chapter 3

### Modular EMLock® Benefits

#### End User Benefits

- Superior appearance
- Reduced installation costs
- Easy maintenance and upgradeability
- No need to ever remove from the frame
- Modular design eliminates need for warranty exchange and transit time

#### Dealer/Installer Benefits

- Quick and easy installation
- Reduced labor
- Field upgradeability in 5 minutes
- Modular design eliminates need for warranty exchange, time in transit and shipping costs

#### Distributor Benefits

- Reduced stocking requirements
- In-house upgradeability for variety of applications
- No need to ever remove from the frame
- Modular design eliminates need for warranty exchange, time in transit and shipping costs

### HiShear Magnetic Locks

**Model 1561 2000 lbs**

**Model 1565 2700 lbs**

SDC HiShear magnetic locks incorporate lateral adjustment of the shear stops (see figure 9), and an integrated door static sensors. One of the great things about adjustable shear stops is that they compensate for door misalignment. In addition, HiShear locks are equipped with a door static sensor to ensure that the door is at rest, and properly aligned before lock activation, also providing quieter operation. Without the relock delay provided by a door static sensor, sudden impact of lock engagement is not only noisier, but can cause what is known in the openings industry as 'racking' of the door, also described by door rattling and severe wobbling towards the bottom of the aluminum glass doors. Overtime, this door racking can cause continued alignment problems.

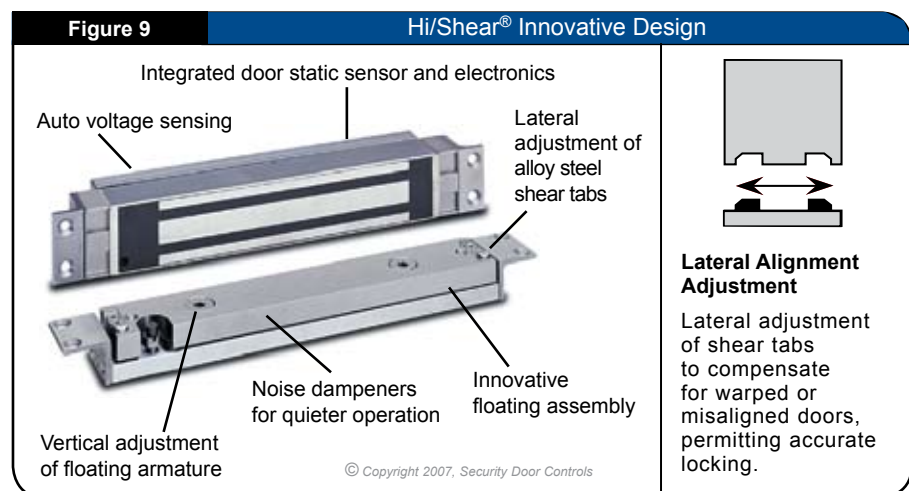
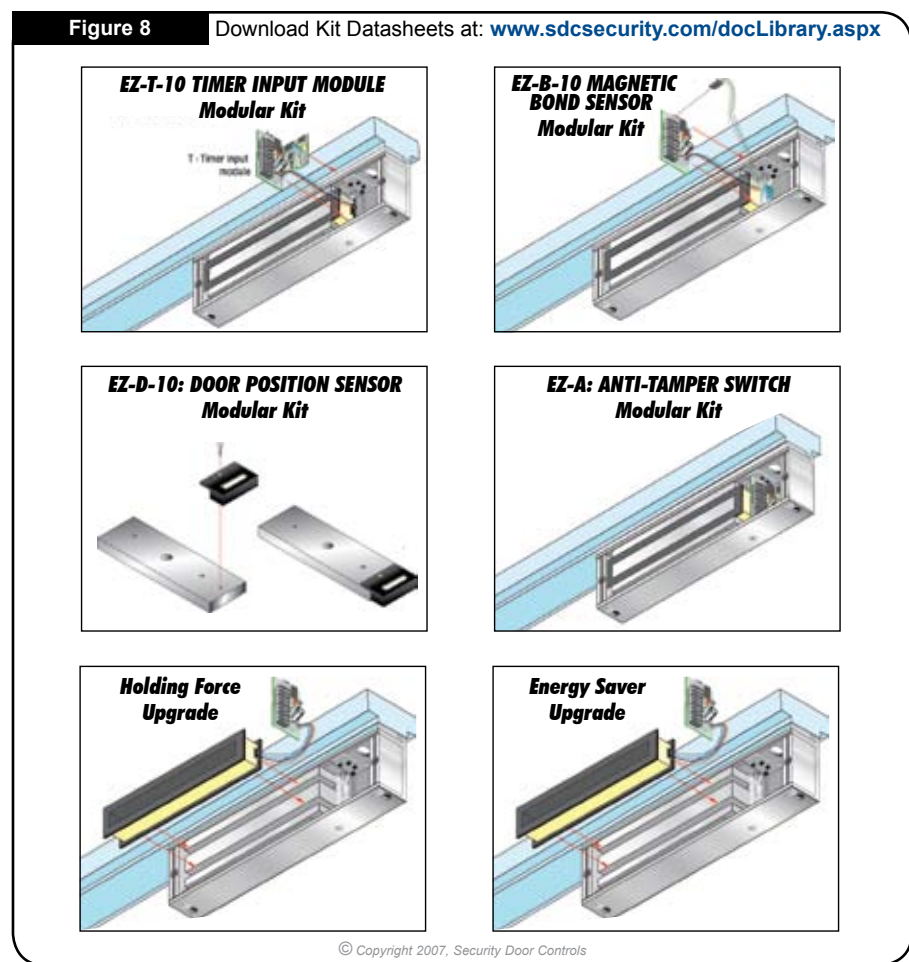

# ESSENTIAL LISTING AND PERFORMANCE CERTIFICATION

By Richard Geringer, V.P. Marketing

October 1, 2007

When choosing a quality electromagnetic door lock, look for the proper listing and performance specifications. The American National Standards Institute (ANSI) has adopted construction and performance standards established by the Builders Hardware Manufacturers Association (BHMA). The ANSI/BHMA A156.23 standard details minimum mechanical, electrical, and holding force requirements. These rigorous standards also place electromagnetic door locks in three categories based on cycle performance capability.

- ANSI/BHMA Grade 1 – 1,000,000 Cycles
- ANSI/BHMA Grade 2 – 500,000 Cycles
- ANSI/BHMA Grade 3 – 250,000 Cycles

All SDC EmLocks are ANSI/BHMA A156.23 Grade 1 Compliant

## BHMA Certification

The BHMA Certification indicates that the magnetic door lock complies with all ANSI and BHMA performance criteria, and that it has passed an independent static pull test, and a dynamic impact test for holding force. To maintain BHMA Certification, locks are periodically re-tested and evaluated by Intertek Laboratories to ensure they continue to meet ANSI/BHMA A156.23 standards. This is the only certification in the industry that verifies that the magnetic door lock design and holding force continues to meet ANSI/BHMA standards.



## UL Listings



The UL Listing confirms that the magnetic lock design is electrically safe and that it is tested for the purpose the product was intended. UL Listings for magnetic locks should include:



GWXT Auxiliary Locks  
CVXJ Burglary Resistant Electrically Operated Door Lock

- **Auxiliary Lock:** Indicates the lock is tested for electrical safety and the purpose for which it was intended.
- **Burglary Resistant Electrically Operated Door Lock:** Look for this listing on all locks with 1200 lbs. or more holding force. This listing indicates that the lock has passed UL test criteria for tampering.
- **UL 10C “Positive Pressure Compliant” and Classified in accordance with Uniform Building Code (UBC) “Fire Test for Door Assemblies”** - This verifies that the lock does not have negative impact on the integrity of fire rated openings. The description will be found on the official UL Listing Auxiliary Lock document.
- **Canadian Listing:** The C preceding the listing symbol indicates that the product is also UL Listed for use in Canada.

## The World of Difference Between

UL ‘Listed’  and UL ‘Recognized’ 

UL’s Component Recognition Service covers the testing and evaluation of components that are incomplete or restricted in

performance capabilities. These components will later be used in complete end-products or systems listed by UL. These components are not intended for separate installation in the field, they are intended for use as components of complete equipment submitted for investigation and subsequent UL Listing.

## US City and State Listings

- **California State Fire Marshal Listed:** This listing is required for California installations. The State of California is well known for consistently setting the highest standards for fire life safety in the world.
- **MEA Listed:** Required for the City of New York by the building department Materials & Equipment Acceptance Division.



**MEA**  
**Listed**

## ISO 9001:2000 Certification

SDC is part of a select group of ISO 9001:2000 Certified manufacturers that practice an internationally recognized quality management program based on continued improvement of daily operations, product quality and customer satisfaction. The SDC quality management system is audited biannually and certified by British Standards Institution (BSI).



The ISO 9001 registration is verification for the customer and product end user that the manufacturer practices a comprehensive quality management program. While the primary customer and end user benefits include higher product quality and customer satisfaction, ISO certification also reduces the customer’s need to conduct audits of the manufacture’s quality control system, promoting ease of national and international trade. A copy of our ISO 9001 registration is available on request.

## A Note to Distributors and Installers

For a competitive edge, specify and promote the listing and performance attributes of the components you are providing with your installations. Include information on code compliance, city and state listings, quality (ISO 9001:2000), performance certification (ANSI/BHMA), specific laboratory listings (UL), service ease and warranty.

## A Note to Building Owners

Know and understand the products being installed, or specify a preferred manufacturer yourself. Request that details about product and application code compliance are supplied with the installation bid, such as, city and state compliance, manufacturer quality management (ISO 9001:2000), performance certification (ANSI/BHMA), laboratory listings (UL), service ease and warranty. This information may be a deterrent to having an inspector reject an installation today, or even at a later date when NFPA 80 changes take effect. Additionally, non-compliance of components could lead to potential liability should a fire or life safety emergency occur in your facility.



[www.sdcsecurity.com](http://www.sdcsecurity.com) [service@sdsecurity.com](mailto:service@sdsecurity.com)  
[t] 800.413.8783 805.494.0622 [f] 805.494.8681  
801 Avenida Acaso, Camarillo CA 93012 • PO Box 3670, Camarillo CA 93011-3670

[www.SDCsecurity.com](http://www.SDCsecurity.com)

**SECURITY DOOR CONTROLS**

