

# E300

## Electromagnetic Cabinet Locks



Eliminate keys and expand the reach of access control systems to drawers, cabinets and lockers – any critical use - where the application of a compact, specialized electromagnetic lock provides a higher level of security. **SDC's E300 micro electromagnetic cabinet locks** provide a connected access control solution that is virtually maintenance free and has a lock status output for remote monitoring and system application needs.

The compact size allows easy installation in small cabinets or restricted areas. No special tools are required.



### MODELS

**E300** Single Magnetic Cabinet Lock, 300lbs



### STANDARD FEATURES

- Wire access chamber with terminal block
- Interlocking quick mount assembly
- Field selectable dual voltage
- Voltage and current spike protection
- Captive lock mounting screws
- Self-drilling and tapping sheet metal screws
- Bond alert status (BAS)



## APPLICATIONS

- Cabinets
- Drawers
- Machine equipment housings
- Display cases
- Gun safes
- Package pass through doors
- Dark rooms

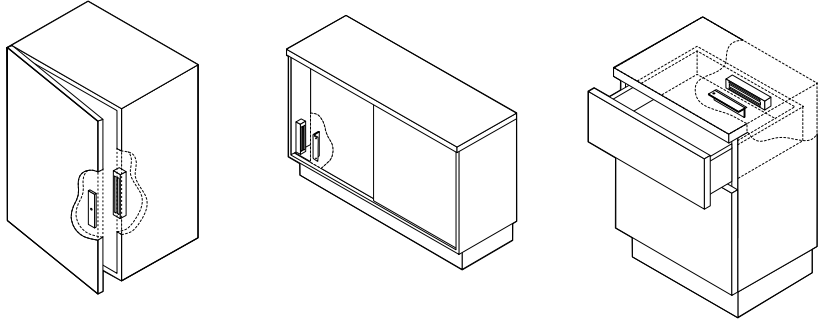

## SPECIFICATIONS

### E300

<b>Housing</b>	Aluminum
<b>Finish</b>	628 Dull Aluminum
<b>Holding Force</b>	300 lbs
<b>Dimensions</b>	7" x 1 $\frac{1}{8}$ " x 7 $\frac{7}{8}$ " Housing 5 $\frac{1}{8}$ " x 1 $\frac{1}{4}$ " x 5 $\frac{5}{16}$ " Armature
<b>Weight</b>	2.5 lbs
<b>Input</b>	12/24 VDC $\pm$ 10% Field Selectable
<b>Current Draw</b>	180 mA @ 24 VDC 360 mA @ 12 VDC
<b>Bond Alert Status (BAS)</b>	SPDT 250 mA @ 30 VDC Resistive

## CERTIFICATIONS

UL 864 Control Units and Accessories for Fire Alarm Systems

## HOW TO ORDER

### FOLLOW STEPS FOR ORDERING

 Designates optional step

#### 1| SPECIFY MODEL

**E300** Single Magnetic Cabinet Lock, 300lbs

STEP NUMBER: 1

ORDERING EXAMPLE: **E300**