



INSTALLATION INSTRUCTIONS

LR100DHK

DESIGN HARDWARE ELECTRIC LATCH RETRACTION KIT

MODELS: 1000R & 1000V

Retrofit Installation Note: 42" or 48" exit devices that have been modified to fit a 36" or smaller opening, may not have the required space to fit the standard E. L. R. assembly. Always verify the distance from the end of the touchpad to the end rail, and if necessary, consult with the factory for appropriate selection.

Place adapter over device and use as a template to drill a .107" Dia. Thru Hole.

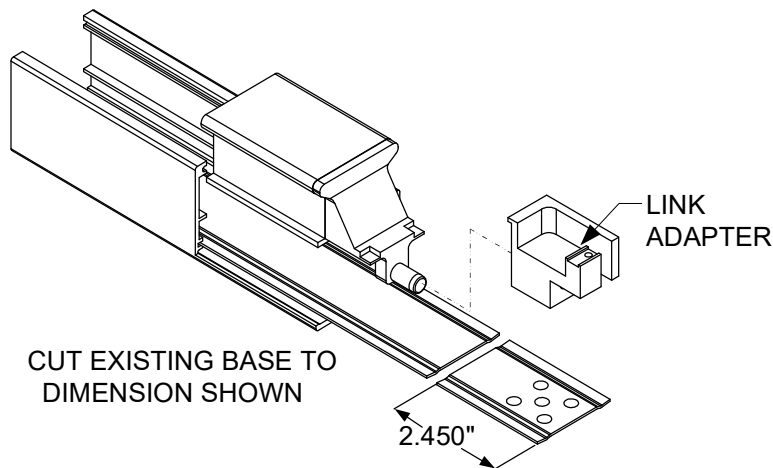

Remove and discard dogging from exit device, before installing the LR100 assembly. Tap a Thru Hole to accept a 6-32 thread and attach the adapter using the supplied 6-32 x 3/8" Truss Head Machine Screw.

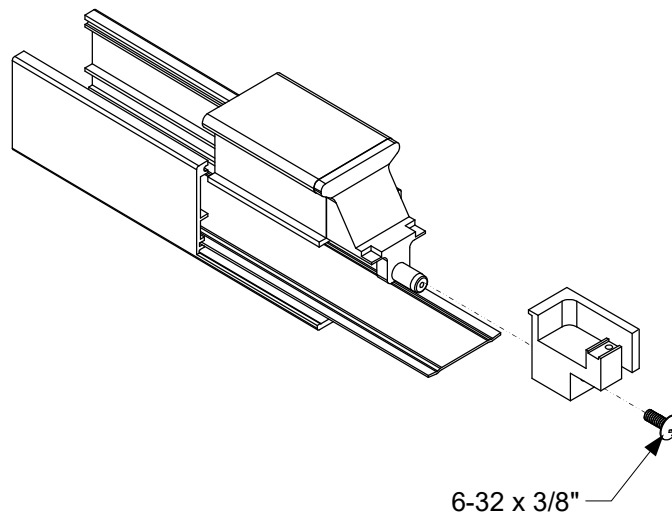

Place E.L.R linkage inside adapter as shown and secure in place with the supplied retaining link and 4-40 x 1/4" Pan Head Screw

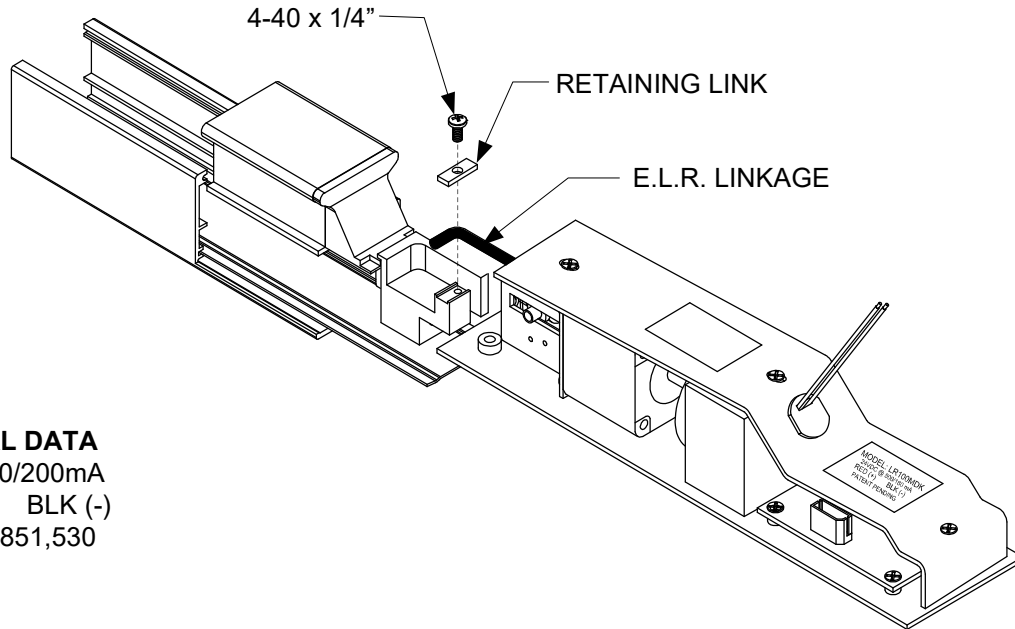
**ELECTRICAL DATA**

24VDC @ 700/200mA
RED (+) BLK (-)
PATENT #8,851,530

Once the linkage is attached, power the unit. This will cause for the E.L.R. to pull towards the exit device. Depress on the push pad, by doing so will properly position the E.L.R. into the appropriate working position. Pull back on the E.L.R. assembly to remove any slack. Then fasten the set screws on the assembly to secure the kit into the device. Release push pad and verify operation by de-energizing and re-energizing the E.L.R. kit to verify that the kit is properly retracting the latch.

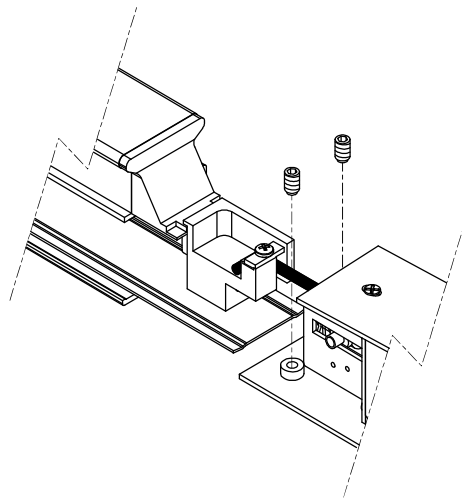
**NOTE Retro-Fitting Vertical Rod Devices:**

Before retro-fitting an electric latch assembly into a vertical device, the following must be done to ensure proper alignment. Disconnect the vertical rods from the device. Install the electric latch assembly as shown above. Once the ELR is properly installed energize it so that the push pad is dogged down, by doing so it will allow for proper alignment for the vertical rods. Finally reconnect the vertical rods to the device and make the proper adjustments.