



INSTALLATION INSTRUCTIONS

Z7500 SERIES SOLENOID FRAME ACTUATOR CONTROLLED MORTISE LOCKSET

A. Door Preparation:

1. Measure desired height from finished floor, mark a horizontal line on door and door edge.
2. Align template on edge of door with applicable horizontal at height line. Check the chart for drilling trim holes on template and mark only holes for lock function being installed.

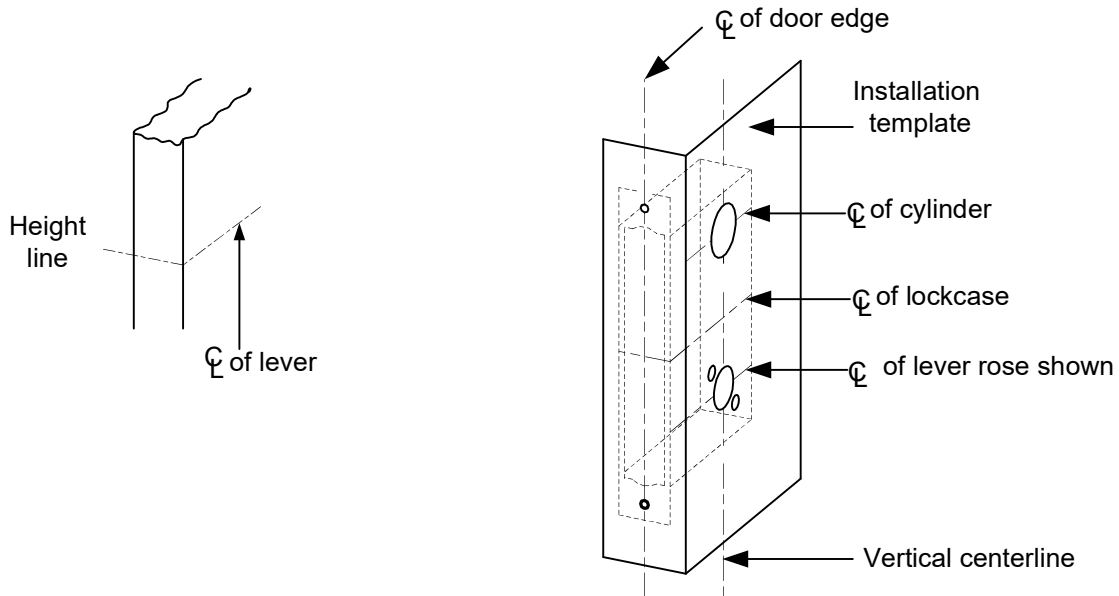

3. Mortise door edge according to measurements on installation template and drill proper holes for trim.
4. Recess for face plate, the dimension is:
L 8-1/32" x W 1-5/16" x D 7/32".

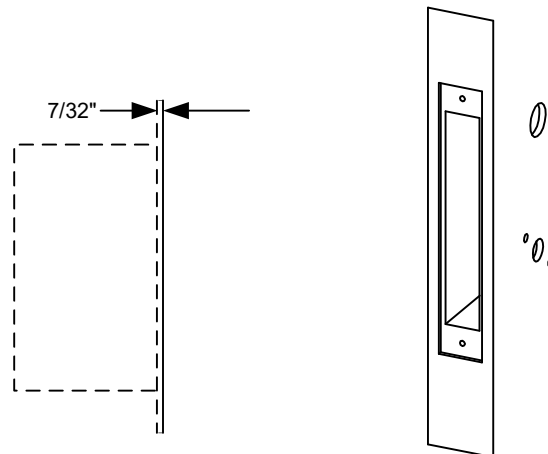

Note:
Rose door prep shown as example.
Escutcheon door prep would differ.



B. Install Lockcase

Make sure the lock hand matches the door hand, use the following diagram to determine the hand of door.

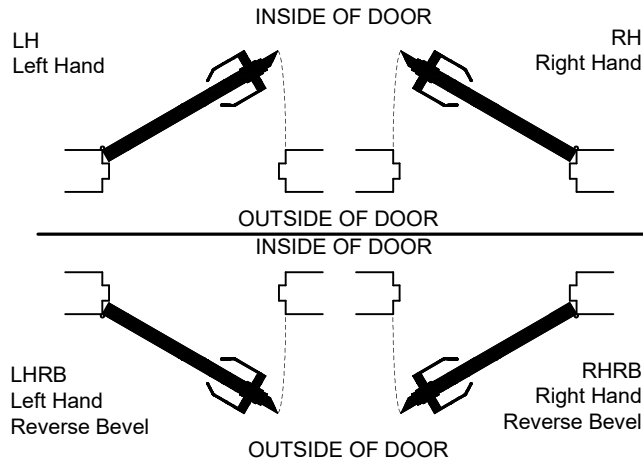

Instructions for changing lock hand:

1. Change latchbolt handing

If the hand of the latchbolt doesn't match the door hand, remove the fixing screw and pull the latchbolt out from lock case. Turn the latchbolt 180 ° to change the handling. Position latchbolt back, into case and fasten it.

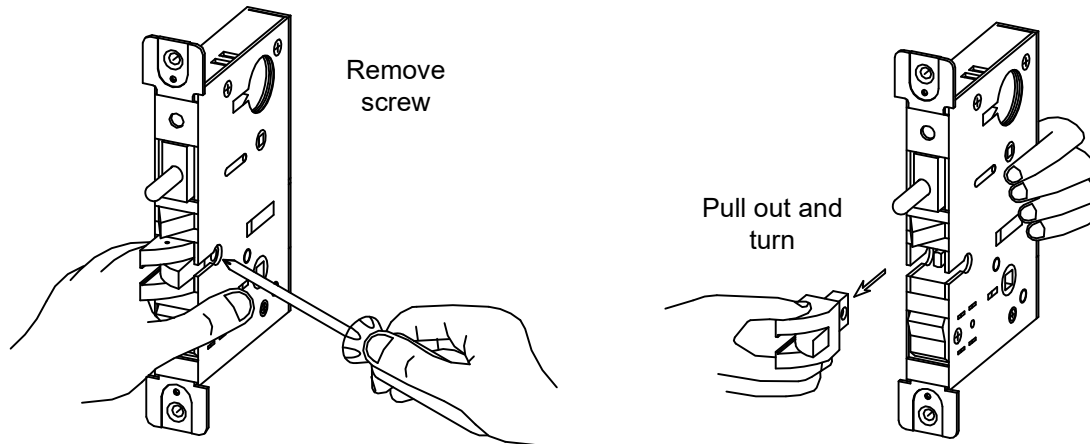

2. Change hand of lock

For RH and RHRB, the catch screw will be on the lock case side. For LH and LHRB, the catch screw will be on the lock cover side.

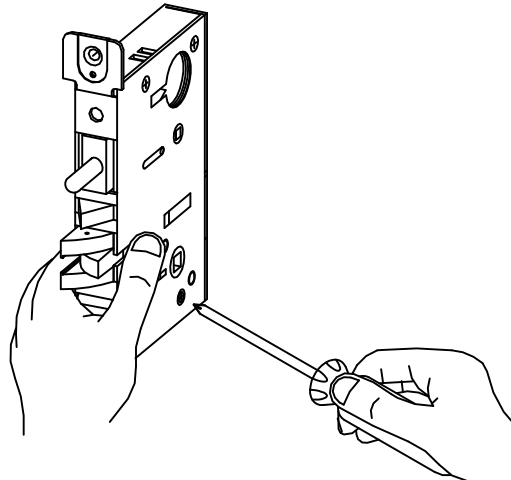

B. Install Lockcase (Continued)

3. Connect wires as shown on the lock cover diagram (Or refer to page 6 of instructions.)
4. Insert lockcase into mortise cut-out and fasten screws to door.

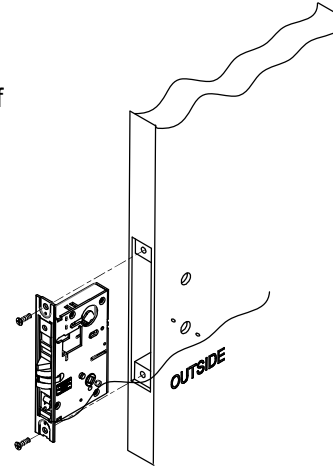

C. Install Spindles

1. Insert spindles as shown

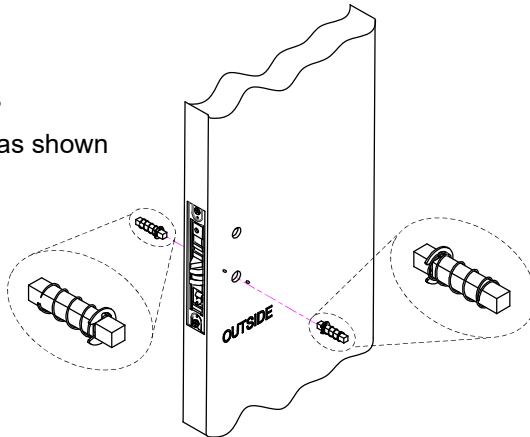

D. Install lever trim

1. Place the reversible spring cage onto the ferrules with arrow pointing in direction of lever rotation.
2. Install outside trim with mounting posts through door and position lever onto the spindle.
3. Install inside spring cage onto the spindle with the arrow pointing in the direction of inside lever rotation.
4. Install inside mounting plate onto spindle. Tighten with provided screw.
5. Cap inside rose over mounting plate.

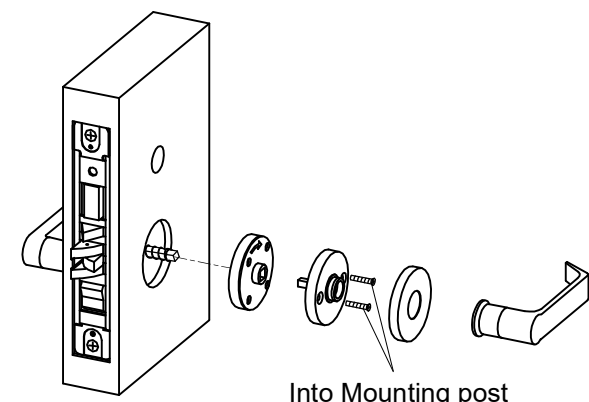
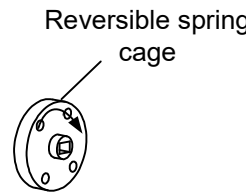
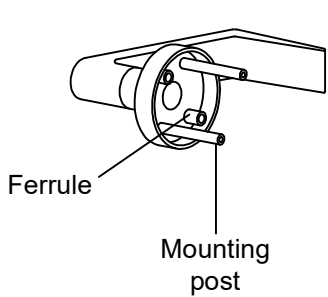

6. Screw inside lever into position and tighten lever collar with supplied spanner wrench.

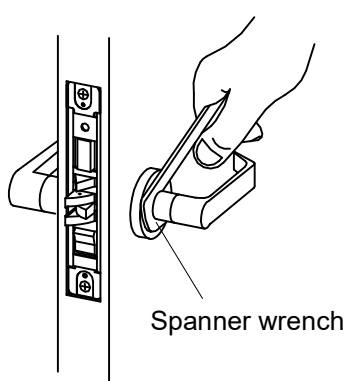
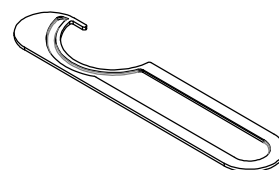

E. Install for 07 lever trim

1. Place the spring, collar and then reversible spring cage onto the outside lever assembly with arrows pointing in direction of lever rotation. Insert spindle into hub of lock case.
2. Install outside lever assembly with mounting posts through door and position lever assembly onto the spindle.
3. Install inside spring cage onto the spindle with the arrows pointing in the direction of inside lever rotation.
4. Install inside mounting plate over spindle and onto the mounting posts of outside assembly. Tighten with provided screws.
5. Cap inside rose over mounting plate and insert second spring.
6. Screw inside lever into position and tighten lever collar with the supplied spanner wrench.

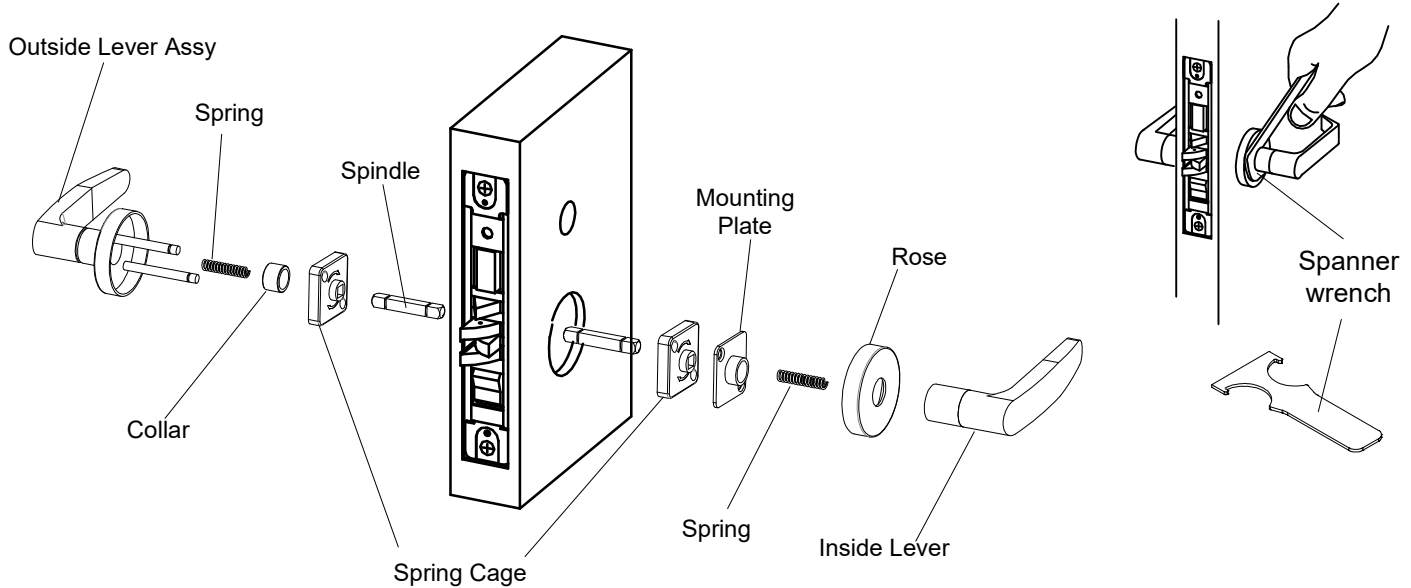

F. Install Cylinder and Armor Face Plate

1. Screw cylinder into threaded hole of the lock case.
2. Tighten the set screw against cylinder(s) by turning clockwise as shown.
3. Install face plate onto the lock case and fasten with supplied screw.

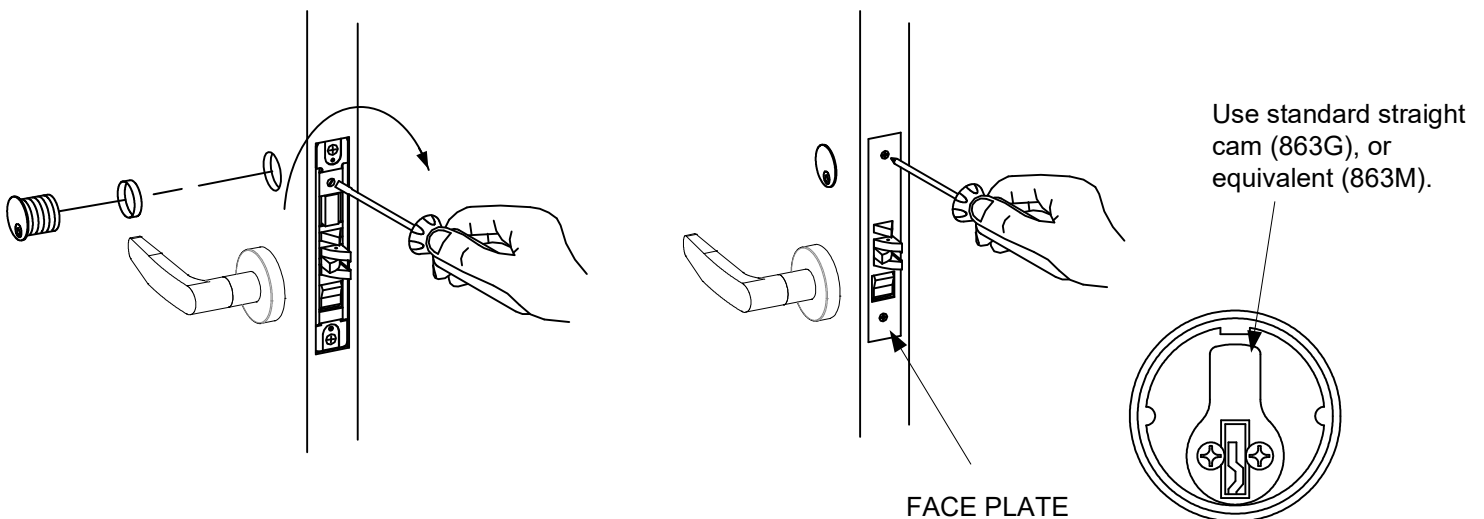



FRAME ACTUATOR INSTALLATION GUIDE

For the frame portion (electric actuator) read these instructions carefully.

To insure a neat and easy installation of the electric actuator into the frame back box when making long wire runs, the heavier gauge wire can be terminated in a junction box above the door. At this point a smaller gauge wire cable may be run from the junction box to the frame electrical black box. This provides for easier insertion of the electric actuator.

For proper operation the voltage as indicated on the lock solenoid must be at the lock location with the load on.

1. The wiring assignments are shown on page 6 as well as on the electric actuator. The lock is supplied with 6" wire leads and will require a min. 10" leads from the conduit.
2. Insert wires into the jamb carefully so they do not interfere with proper positioning of the lock in the cut-out.
3. Insert lock and secure with screws provided.
4. While the actuator is energized, verify that the appropriate function is working properly. The actuator is factory set for a 1/8" door clearance. If the clearance between the door and jamb is more or less than 1/8" then the following adjustment must be made (refer to Fig. 2).

- A. Loosen the Allen screw in the plunger.
- B. Remove plunger head.
- C. Turn each adjustment screw **equally** in desired direction.
Counter-clockwise for wide gaps – clockwise for narrow gaps.

IMPORTANT:

ADJUSTMENT SCREWS MUST BE TURNED EQUALLY TO OPERATE FREELY.

- D. Replace plunger head and test lock. Lever should lock when actuator is energized.
5. If ordered with Latch position sensor, then adjustment is factory set for 1/8" door clearance and is adjustable for wide and narrow door gaps. If adjustment is required please follow steps A, B & C.

Refer to Fig. 2.

- A. Loosen the two screws on the side of the dust box.
- B. Move the switch assembly forward or back to desired position.
Example: For 3/16" door gap move the switch assembly forward 1/16".
- C. Tighten screws.

Strike Plate Dimensions

- For Metal Frames: 4-7/8" x 1-1/4" x .0937" Standard ANSI
- For narrow metal frames: 8-1/2" x 1-1/4" x 1/8"

ID Requirements

- Standard Actuator: 12" x 2-1/2" x 1-3/4"
- Narrow Backset Actuator: 12" x 2-1/2" x 1-1/4"

Fail Safe: Continuous duty – locked when energized

UL Listed: Electrically controlled single point locks or latches

FIG. 1

Electric Actuator.
Solenoid points up.

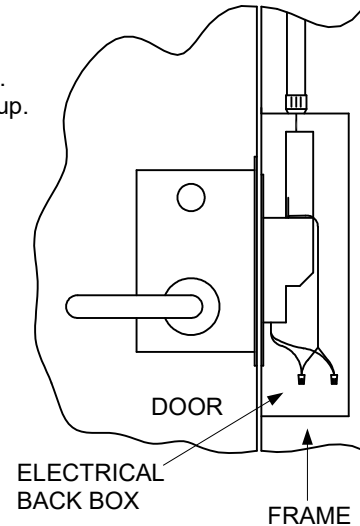
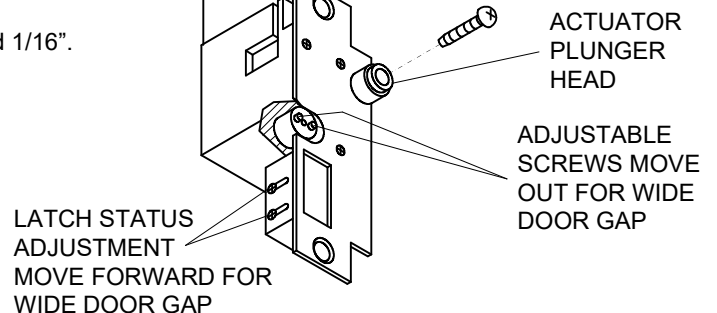
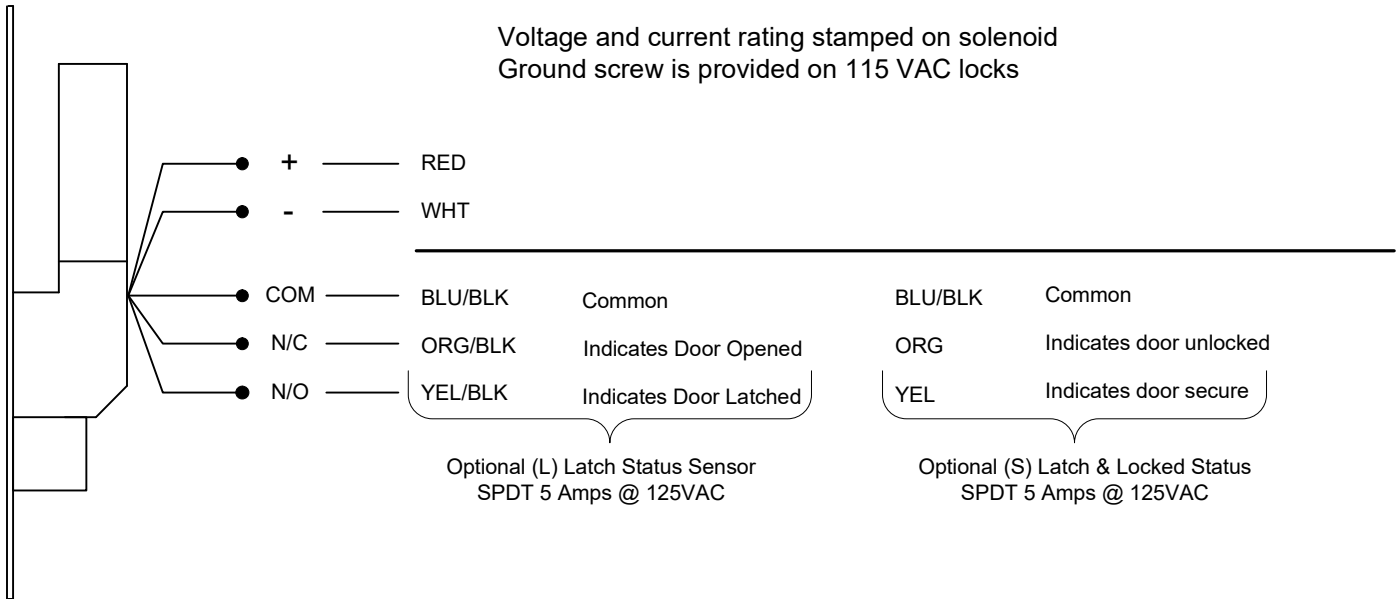

FIG. 2





Standard wiring



Optional: SC-10 - 10ft Cable, Input Power Socket Connector

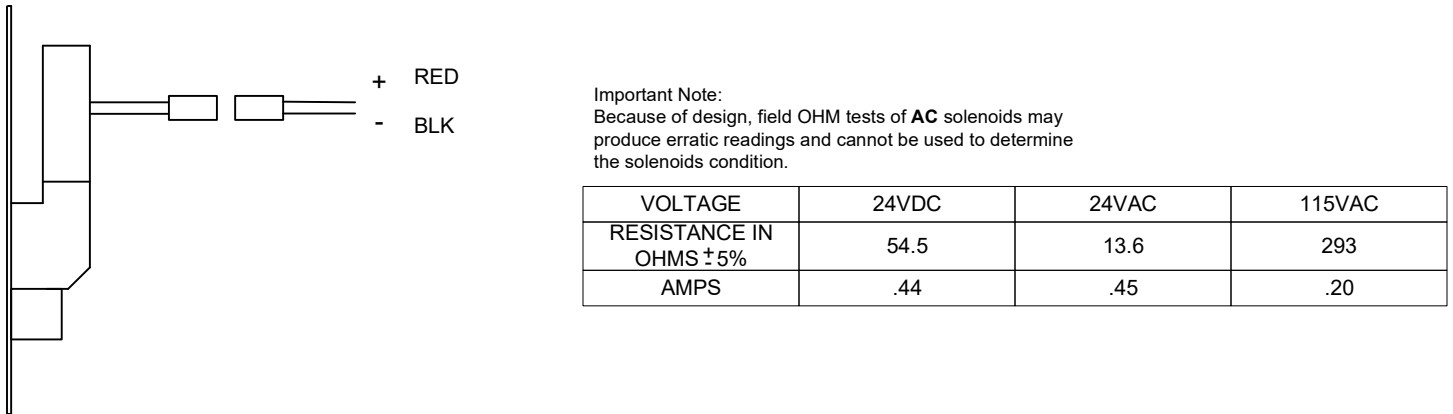

Optional: SC-10-5 - 10ft Cable, Input Power & Monitoring Socket Connector

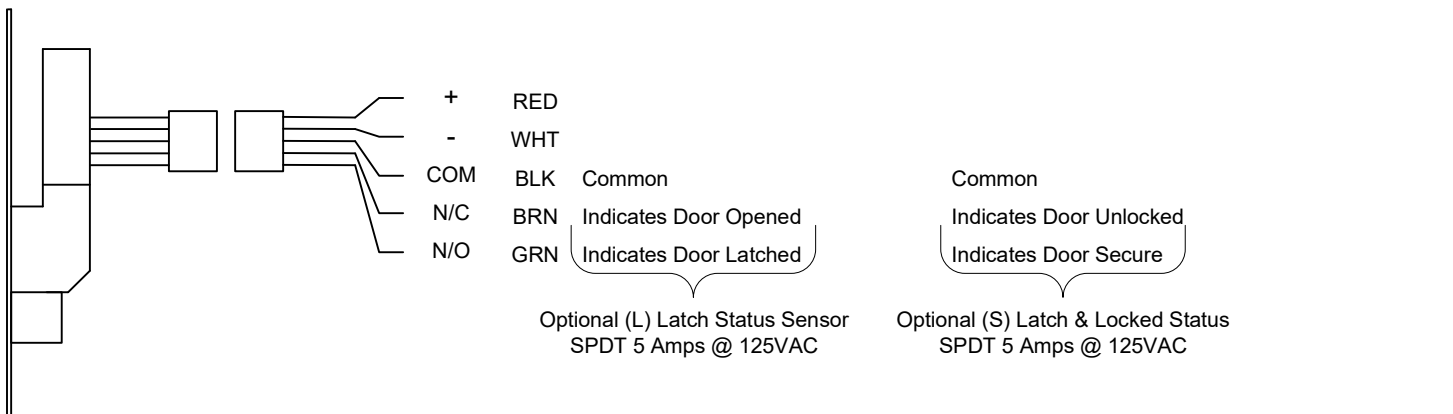



FUNCTIONS

7530

Mortise is locked while energized and is unlocked by a remote switch or by means of a key from either side.

Suggested: communicating locks, man trap

7550

Mortise is locked while energized and is unlocked by remote switch or by means of an outside key or by rotating the inside lever.

Suggested: stair tower doors, classrooms, laboratories, offices, man trap.

7560

Mortise is locked and is unlocked when energized by a remote switch or by means of a key from either side.

Suggested: communicating locks, man trap

7570

Mortise is locked is unlocked when energized by remote switch or by means of an outside key or by rotating the inside lever.

Suggested: stair tower doors, classrooms, laboratories, offices, man trap.

TROUBLE SHOOTING HiTower® 7500 SERIES

The 7500 Series is a Electric Power to Lock Unit which is failsafe in that it unlocks when power is removed. The most commonly used function is the 7550 model which is locked when energized on the outside and free on the inside egress. Models 7530 & 7560 are locked on both sides.

PROBLEM	CAUSE	SOLUTIONS
(1) Power on controller plunger does not throw.	1A Insufficient voltage	1A Check voltage with a meter at the lock farthest from source with all locks energized. Meter should indicate the same voltage stamped on the solenoid body. If voltage is low, either too small of a wire gauge was used or there is too great of a load on the line.
	1B Binding caused by uneven plunger adjustment.	1B Adjust plunger evenly (Refer to Fig 2).
	1C Electric portion wired wrong.	1C Review wiring diagram on side of lock & instruction sheet.
(2) Latch bolt throws only part way, lock chatters or buzzes.	2A Door alignment does not permit latch bolt to enter strike	2A Proper alignment must be achieved by correctly hanging the door in a properly installed frame. Modifying the lock and strike will not remedy the problem. Modification will void UL listing and warranty.
(3) Inside lever is locked, outside is free.	3A Incorrect handing	3A Remove mortise lock and reverse hand.
(4) Latch position switch does not signal properly.	4A Adjustment is off.	4A Adjust sensor. See Step 5 of instructions.